

**NATIONAL FESTIVAL RULES
OF THE
AMERICAN TURNERS**

**PART I
Organization and Management**

**ARTICLE 1
FUNDING, ACCOUNTING & FINANCIAL REPORTING**

The starting point for all National Festivals is the preparation of a contract between the American Turners and the Turner Society that has been awarded the Festival by the American Turners National Council. A required approved addendum to the contract is a budget in support of the total Festival estimated cost that has been incorporated within the body of the contract. The net cost of the National Festival is fully paid from the American Turners Festival Fund. The budget breaks down the estimated net cost into major categories, for financial reporting and accounting purposes, to arrive at the estimated new cost. A sample contract is attached as Exhibit I. A sample budget is attached as Exhibit II. Additional categories may be added as needed or deleted if not needed.

It is the responsibility of the Treasurer of the Local Festival Committee to establish a Festival bank account in the host city and to set up accounts for recording receipts and disbursements in conformity with the approved contract and the categories as defined in the budget. It is also his/her responsibility to be sure that all disbursements are approved in accordance with the requirements of the contract and to prepare and distribute the financial reports and documents as specified. It is the responsibility of the Chairperson of the Local Committee to be sure that expenditures do not exceed the limits as agreed on in the contract and budget. The Turner National office and the National Festival Auditor are responsible for reviewing the major expenditures and the local Society's monthly financial reports to be sure that the Local Committee keeps its expenditures within the terms of the contract and budget.

It is the responsibility of the National Treasurer to write checks for major expenditures (as provided for in the contract and budget) directly from the National Festival Fund. The National Treasurer also writes occasional minor checks to reimburse the Festival expenses of the National Chairpersons of the Cultural and Physical Education Committees directly from the National Festival Fund. Any disbursements made directly from the Festival Fund is reported to the National Festival Auditor each month.

The National Festival Auditor works with the National office and the Local Festival Committee in drawing up the Festival contract and budget. He/she is also responsible to set up worksheets in order to compile consolidated financial reports derived from the records maintained by the Treasurer of the Local Festival Committee and the National Treasurer. He/she is to review the monthly bank reconciliation of the Local Festival Treasurer and review the expenditures for accuracy, proper approvals and compliance with the contract and budget. Any discrepancies must immediately be brought to the attention of the Local Festival Committee and the National office. At the end of the Festival he/she is to review all the accounting records and bank statements from both the Local Festival and the National Treasurer and prepare final financial reports from the audited Treasurer's records and his/her own worksheets. He/she must determine the amount due to the Local Society for its share of the net revenue items as specified in the contract and budget and wind up by preparing a final comparative Festival financial report that compares actual amounts to the budget amounts.

**AMERICAN TURNERS 53rd NATIONAL FESTIVAL
EXHIBIT I – SAMPLE CONTRACT**

CONTRACT AGREEMENT

For the purpose of sponsoring and promoting the 53rd National Festival of the American Turners to be conducted in ___(city)___, ___ from ___ through ___, 20___, this contract/agreement has been entered into between the National Council of the American Turners (National) of Louisville, Kentucky and the ___(Turner Society)___ of ___(city)___, ___(state)___.

TO WIT:

(Part 1) For purposes of determining an anticipated budget of financial expenditures and receipts for the above named Festival, the attached projected budget (Part A & B) has been accepted and agreed to by all parties to the contract/agreement.

Realizing that deviations from any projected budget may become necessary, it is agreed by all parties that ___(Society)___ can, in their promotion of this Festival, deviate from the attached net budgeted expenditure of \$___ but not in excess of 5% without prior consultation and agreement with the National. It is further agreed that ___(Society)___ may deviate from the line item budget figures, but not in excess of 10% of any figure shown in the attached budget. The net total of such deviations shall not exceed 5% as aforementioned, without prior consultation and agreement with the National.

(Part 2) All contracts entered into by ___(Society)___ with any third party must be approved and ratified by the National before becoming binding upon the American Turners.

(Part 3) American Turners Festival Fund:
Festival Accounting Procedures, etc.:

It is further agreed that the host Society ___(Society)___ will establish a “National Festival Checking Account” in an approved banking institution for purposes of conducting this 53rd National Festival. Signature requirements for the “National Festival Checking Account” shall be as follows:

- (a) Expenditures of \$1000.00 or less:
Signature of the ___(Society)___ Festival Committee Treasurer
and co-signed by the ___(Society)___ President or the Festival Chairperson.
- (b) Expenditures over \$1000.00:
To be paid directly by the National office from the Festival Fund.

The National shall transfer monies from the “American Turners National Festival Fund” account into the above stated “National Festival Checking Account” when, in the opinion of the National, these transfers of monies are necessary for the promotion of the 53rd National Festival.

To provide an accurate accounting for the 53rd National Festival all expenditures required in promoting this Festival are to be made by check. Any single expenditure of \$1,000.00 or more shall be made direct from the National office from the Festival Fund account. Expenditures under \$1,000.00 shall be made from the “National Festival Checking Account” and not from any account of ___(Society)___ or any other account.

All revenues derived from activities directly related to the 53rd National Festival, as covered in this contract, shall be immediately deposited intact in this “National Festival Checking Account” and into no other

account. These sources of revenue shall include receipts from registration and entry fees, late fees, admissions to Festival events, donations and such other receipts as mutually agreed to by all parties to this agreement.

Book records of cash receipts and disbursements shall be kept so that monthly reports showing monthly and accumulated to-date figures can be prepared in compliance with the account caption breakdown as shown on the attached approved summary budget statement. This monthly report will also show the bank balance at the beginning of the month and at the end of the month. The month end bank statement balance shall be reconciled to the monthly report. This monthly report must be approved by the 53rd Festival Chairperson and the Society President of __ (Society) __ and forwarded to the American Turners National Office no later than the 15th day of the following month.

Following the close of the 53rd National Festival, and after full and proper accounting, reporting, and auditing, the NET PROFIT derived from any income producing sources of the 53rd National Festival is to be given to the American Turners. The host Society's portion of such profits shall not be paid until all awards, audits and other Festival related business has been satisfactorily completed. Part B of the Budget with the "actual" column completed and an audit of the 53rd National Festival income and expenditures is to be completed and turned into the American Turners National Office prior to December 31, 20__.

(Part 4) It is further agreed that all supplies and equipment purchased for this 53rd National Festival shall be the property of the American Turners, and forwarded to them following the Festival; or, if agreed to by the National, such property may be disposed of by sale. The proceeds of such sales are to be credited to the cost of equipment purchases for the Festival.

Any revenue or costs related to the Festival Banquet and other SOCIAL functions, entertainment, meals served or bar sales provided by __ (Society) __ and any sales of souvenirs and Ad Book during the period of the 53rd National Festival shall be the full responsibility of __ (Society) __ and any net proceeds or losses related to these functions shall be retained 100% by __ (Society) __. Receipts and expenditures from these activities shall not be entered into the "National Festival Checking Account" described above.

(Part 5) It is further agreed that __ (Society) __ will arrange for adequate public liability and theft insurance to cover all Festival sites and for participants for the period of the 53rd National Festival. The National shall pay for the cost of such insurance as provided for in the approved budget.

(Part 6) No less than 18 months prior to the commencement of the 53rd National Festival, the __ (Society) __ Festival Committee shall begin holding meetings no less than monthly. A copy of the detailed minutes of said meetings shall be forwarded to the American Turners National office as soon as available. If such minutes are not received timely as provided above, the National will send a representative to __ (city) __, __ (state) __ to investigate, at the expense of __ (Society) __.

(Part 7) Penalties for non-compliance to the terms of this contract:

- (a) If any cash receipts are deposited in an account of __ (Society) __ or any account other than the "National Festival Checking Account", __ (Society) __ shall be assessed a penalty of 25% of such deposit. All receipts must be deposited in the "National Festival Checking Account".
- (b) If __ (Society) __ pays any Festival Expenses in cash from Festival cash receipts or by check from a bank account of __ (Society) __ or any other account other than the "National Festival Checking Account", the National will not reimburse __ (Society) __ for any such expenditure. All expenditures shall be made by check and only from the "National Festival Checking Account" or by the National Treasurer from the American Turners Festival Fund.

This 3 page contract/agreement and the 2 page attached budgetary supplement have been reviewed and approved by all parties to this contract/agreement; and, the authorized officers for each party hereby

attest to this contract/agreement on behalf of their respective organizations that are parties to this contract.

Dated at __ (city) __, __ (state) __, this ___ day of _____, 20__.

For the __ (Society) __:

_____, President, _____, Secretary

_____, Festival Chairperson (Seal)

For the American Turners:

_____, President, _____, Secretary

(Seal)

AMERICAN TURNERS 53rd NATIONAL FESTIVAL

BUDGET SUMMARY (part A)

EXPENSES	\$
Less:	
Donations Received	-

NET EXPENSES before Revenue Functions	\$
Less:	
½ of Net Revenue Functions (see schedule)	

NET COST OF FESTIVAL TO AMERICAN TURNERS	\$

NET REVENUE FUNCTIONS SCHEDULE

REGISTRATIONS:

Includes Entry Fees, Late Fees, Admission Fees & Badges

Income	\$
Costs	-

Net	\$

½ of Net Revenue Functions Due To Host Society (see above)

Dated _____, 20____

For Festival Host Society: _____, Secretary

For American Turners: _____, Secretary

AMERICAN TURNERS NATIONAL FESTIVAL

EXHIBIT II – SAMPLE BUDGET (part B - detail)

Error! Not a valid link.

**ARTICLE 2
NATIONAL COUNCIL**

1. A National Festival is authorized by the National Council of the American Turners.
2. The National Council entrusts the Local Festival Committee with the local management of a Festival as determined by the rules governing Festivals. The National Council will make assistance available through the NHPE and the NCE Festival Committees.
3. A National Festival shall be held every fourth year, one year before the Olympic Summer Games.
4. The National Council shall fix the time and place for holding the next National Festival. If possible, this designation will be made at the first American Turners National Convention after the National Festival.
5. In case a National Festival cannot be held at the place designated by the National Council, or there being no application from any Society, City or District for holding the Festival, at the time of the convention, the National Council shall inquire of the Districts and Societies whether they are willing to take over the Festival. After consultation with such Districts and Societies, the National Council shall designate the place and time for holding the Festival.
6. The Festival shall last no longer than five days – preferably in late June and /or early July.
7. The activities at a National Festival are attempts by means of exhibitions and competitions to demonstrate the ideals and standards of work in American Turner Societies.
8. Work in Cultural Education, as well as Physical Education, shall be shown.
9. The physical activities shall consist of: Society competition, Team competition, Individual competition, Model Drill, Mass exercises and special games for Active men and women ages (18-23) and (24-29), Senior men and women ages (30-up), Junior boys and girls ages (14-17), Youth boys and girls ages (7-9) and (10-13)

**ARTICLE 3
NATIONAL HEALTH AND PHYSICAL EDUCATION COMMITTEE**

1. Upon recommendation of the Local Technical Committee, the National Health and Physical Education Committee (NHPEC), shall name one (1) or more technical leaders (chairperson) of the Festival as Festival Leaders. The leader is the local representative of the NHPEC, if applicable, or the Society Physical Education Instructor. He/she shall conduct the Mass Exercises and shall see that the areas of competition and exhibition facilities are prepared and equipped as prescribed by the rules and regulations, and as demanded by the work-plan of the Festival. He/she is to see that facilities are completely ready by the opening day of the Festival. All expenses involved in this preparation will be paid by the

National Festival Fund.

2. The program shall be prepared by the National Physical Education Chairperson and the National Cultural Education Chairperson, in consultation with the Local Technical Committee and Local Committee on Cultural Education. The program to be sent to Societies at least six (6) months prior to the Festival. Any expenses incurred in this preparation shall be approved by the Chairperson of each committee and paid from the National Festival Fund.
3. The judges, referees and all other officials necessary for all phases of physical competition shall be appointed by the Local Festival Committee with the approval of the NHPEC.
4. The NHPEC supervises the activities of the judges and of the Data Entry, Auditing and Awards Committee.
5. The Festival Data Entry, Auditing and Awards Committee shall have two (2) people on site for each event to enter and verify results, and immediately make the results available and post the complete results of the various competitions as soon as possible.
6. After a review by the Data Entry, Auditing and Awards Committee, the place and points of every award winner shall be published in the Turner Topics
7. The Chairperson of the NHPEC shall be Chairperson of the College of Judges. He/she is the chief referee of the Festival, to whom all protests and appeals must be made in writing and be as explicit as possible.
8. A member appointed by the NHPEC Chairperson shall act as secretary of the College of Judges.
9. Members of the NHPEC shall participate as supervisors, assistant supervisors and leaders.

**ARTICLE 4
THE NATIONAL CULTURAL EDUCATION COMMITTEE**

The National Chairperson for the National Cultural Education Committee (NCEC) shall have complete charge of all phases of cultural competition in conjunction with the Local Cultural Committee. A separate booklet on rules for these activities has been published and entitled "Rules and Guidelines for Cultural Programs and Competition of the American Turners".

All cultural participants of the National Festival shall be required to pay a registration fee. The cultural registration fee shall be a \$5.00 minimum per entrant. Participants entering both physical and cultural competitions shall have the cultural registration fee waived. Any cultural participant that mails/ships their entries in, but does not attend the Festival in person, must pay the cultural registration fee and the cost of postage to return their entries after the Festival.

**ARTICLE 5
OFFICIALS
College of Judges**

SUPERVISORS

1. Members of the NHPEC shall be assigned to the various activities by the NHPEC Chairperson, to assist the Local Chairperson of the various activities at the time of the Festival. They (NHPEC) shall be appointed these duties at least six (6) months prior to the Festival.

Supervisors shall be appointed for:

Apparatus Exercises (Artistic Gymnastics)	Judges and Judging
Track and Field Events	Data Entry, Auditing and Awards

Team and Individual Events
Marching Drill and Society Free Exercises
Special Events

Publicity
Volleyball
Swimming

ASSISTANT SUPERVISORS

1. The NHPEC shall appoint as many Assistant Supervisors as it deems necessary. The Assistant Supervisor shall be in charge of a group of competitors. He/she shall have charge of the judges and competitors in this phase of work. These supervisors may be taken from the list of reserve judges. They are responsible for the delivery of score cards to the Data Entry, Auditing and Awards Committee.
2. By the end of six weeks after the Festival, each Supervisor and Assistant Supervisor shall send to the Chairperson of the NHPEC a report on his phase of work and suggestions for improvements.

REGULAR JUDGES

1. The regular Judges shall be selected from the Instructors/Coaches and leaders of Societies taking part in the Festival. Societies, therefore, are urged to send their Instructors/Coaches to National Festivals. If the Instructors/Coaches described above are selected by the NHPEC, they will be urged to serve as Judges, and will be fairly compensated as determined by the Festival Host Society.
2. Upon recommendation of the NHPEC, the National Physical Education Chairperson shall appoint as many (SPECIAL JUDGES) as are necessary to carry out the program of competition.

SPECIAL JUDGES

1. Those certified for rating advanced gymnastics, volleyball referees and diving shall receive payment established and approved by the NHPE Chairperson. This payment is made after the Festival, upon presentation of a voucher signed by the supervisor of the event, showing that the judge has performed his or her duties.
2. Special Judges shall not be Instructors of Societies taking part in the competition.
3. The first meeting of the Judges shall be held before the start of the competitions. At this meeting, the work plan shall be explained, and the judges shall receive all information relative to their work. This meeting shall be considered the beginning of a Judge's official duties. Attendance is mandatory.
4. Remuneration received by Judges shall be paid from the Festival Fund.

ARTICLE 6 THE LOCAL FESTIVAL COMMITTEE

1. Approximately two years before a Festival, members of the Society(ies) of the City or District in which a Festival is to be held shall meet to select a Festival Committee.
2. At the beginning, this committee should be composed of not less than ten (10) people.
3. The Festival Committee organizes itself by the election of a Festival Chair, a Vice-Chair, a Secretary, and a Treasurer, all of whom shall be members of the Finance Committee. Of those four (4) positions no one person can hold two (2) of the above positions. The committee thereupon selects the leader of the six (6) main committees. The Festival Chairperson is recommended by the Local Festival Committee, approved by the NHPEC and the National Council.
4. The main committees are:
 - a) Technical (Physical Education)
 - b) Cultural Education
 - c) Finance (Ways and Means)

- d) Publicity
- e) Housing and Entertainment (including Decorations, Food, Banquet and Parade)
- f) Data Entry, Auditing and Awards

5. The six (6) main committees, as time progresses, shall be divided by the Festival Committee, into as many sub-committees as are necessary for the accomplishment of the tasks required. The **Leaders** of these sub-committees, by virtue of their office, shall become members of the Local Festival Committee.
6. The Data Entry, Auditing and Awards Committee shall work in close association with the Local Technical and Cultural Committees in processing the necessary awards.
7. The Festival Committee shall determine the number of persons on every sub-committee.

**ARTICLE 7
PUBLICITY**

1. Advertisement and publicity prior to the Festival lies in the hands of the Local Festival Committee.
2. A large bulletin board should be erected at some conspicuous place indoors, on which general results are to be posted, as well as possible changes in plans, schedules, etc.
3. Copies of results of each type of competition shall be distributed by the Local Festival Committee and /or Publicity Supervisor to the newspapers and Turner Topics as soon as the results are known and have been verified.
4. The Local Festival Committee shall provide an amplifying system on the field and in the gymnasium, and other venues, where various results, schedule changes, and other information may be announced. Expenses involved are to be paid by the Festival Fund.

**ARTICLE 8
DATA ENTRY, AUDITING AND AWARDS COMMITTEE**

1. This Committee shall consist of a Committee Leader, an assistant and any necessary workers.
2. The Committee Leader and his/her assistant shall be approved by the NHPEC Chairperson upon recommendation of the Local Festival Committee.
3. The expenses of the Committee Leader and his/her assistant shall be paid by the National Council out of the Festival fund.
4. Other members of the Data Entry, Auditing and Awards Committee shall be selected by the Local Festival Committee Chairperson and shall receive payment for services rendered.
5. The Committee Leader, soon after his/her appointment, shall make all necessary arrangements with the NHPEC and the Local Committee relative to rooms for his/her committee, equipment and necessary materials.
6. The Committee Leader and his/her assistant shall have full charge of the personnel of the committee, e.g. assigning the work, arranging working hours, mealtimes, etc.
7. The general forms for the auditors shall be furnished by the Local Committee, with recommendations by the Chairperson of the NHPEC.
8. All necessary computers, calculators, typewriters and writing instruments shall be furnished by the Local Festival Committee.

9. This Committee will use the American Turners Festival software program provided by the National Office. The use of no other program will be allowed.
10. Fred Sontag (Clinton Turners) shall provide technical assistance to this Committee relative to use of the American Turners Festival software.
11. This Committee Leader shall make arrangement for Fred Sontag to train him/her regarding the software to be used. This training can be in person or via telephone or e-mail. Any expenses relative to this training incurred by Mr. Sontag shall be reimbursed from the Festival Fund.
12. All members of this Committee responsible for data entry will be trained by the Leader of this Committee and/or Fred Sontag in advance of the Festival on the procedures to be followed for proper use of the American Turners Festival software.
13. In all computation, fractions of points or percentages shall be recorded in decimals to at least three (3) places – (.001).
14. The first meeting of the complete Data Entry, Auditing and Awards Committee shall be on the day preceding the opening of the Festival. From this time until the lists have been revised – immediately upon completion of the competitions, the committee is in continual session.
15. The sessions of the auditors are closed. Only members of the NHPEC and Chairperson and Supervisors of Publicity shall be permitted to enter.
16. A member of the Data Entry, Auditing and Awards Committee shall be present at all times during the registration period on the first day of the Festival.
17. This Committee is responsible for procuring all awards for the Festival, such as physical and cultural competition, honor and special awards.
18. Programs of presentation shall be arranged during and at the conclusion of the Festival.
19. The Leader of this Committee should be familiar with all rules contained in this Rulebook pertaining to awards for each event.
20. Either the Committee Leader or a designated member of this Committee must be present at all awards presentations, whether it is at a venue immediately following the conclusion of an event, or at a later time at the Turner Hall or another designated facility.
21. Awards shall be displayed in a prominent and safe location before and during the Festival.
22. Refer to Supplemental handbook for detailed requirements.
23. Scoring and Awards Flow Chart:
The Festival database, scoring programs, award ceremonies and result summarizes are all interrelated. Communication between the NHPEC, National Cultural representatives, Festival Chairperson, Computer Programmer, Home Society data entry designee (registration person), Individual event designee, Award personnel and later Web Master is essential. Illustrated below is a working model.

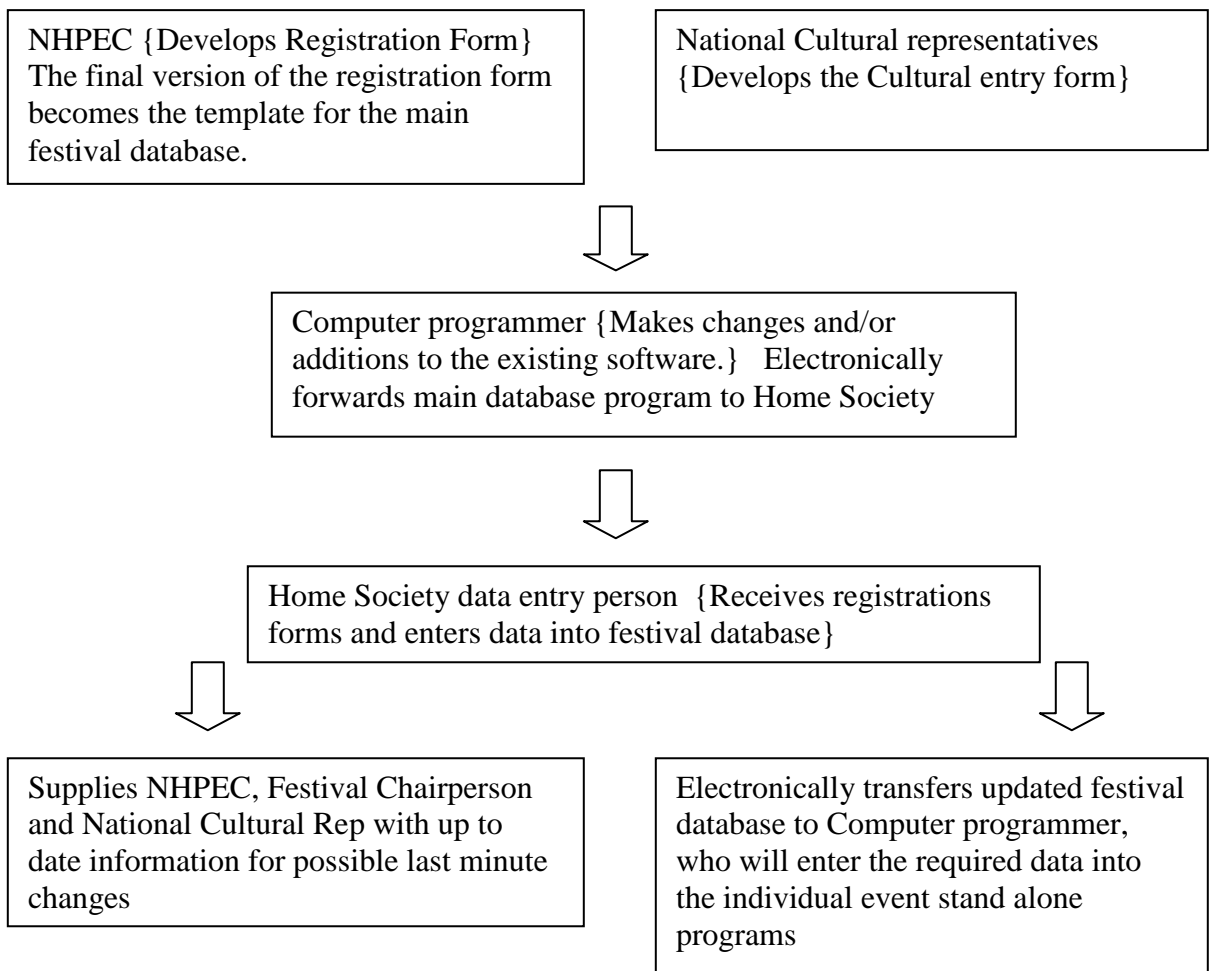

Lotus based programs:

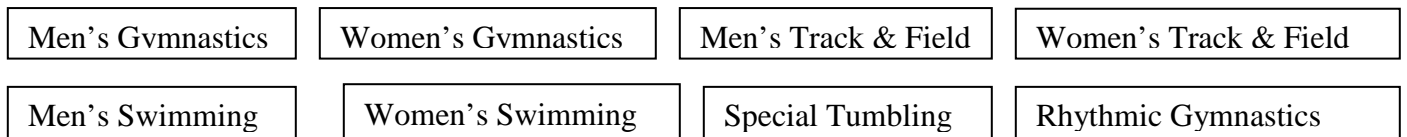

Spreadsheet based programs:



Free Exercise

Other: i.e. – golf, tennis

Final Summary sheet

**ARTICLE 9
THE LOCAL TECHNICAL COMMITTEE**

The functions of this Committee shall be as follows:

1. To arrange and equip all venues, dressing rooms and meeting places, locations of which shall be clearly marked with signs, according to the directions of the NHPEC.
2. To place at the disposal of the Festival Leader(s) sufficient personnel to assist in the placement and removal of all apparatus and equipment used during the Festival.
3. To secure, in a convenient location, meeting places for judges and officials.
4. To provide sufficient personnel to keep the field and gymnasium areas of competition clear of spectators.
5. To provide the necessary equipment for musical accompaniment and amplification for the activities requiring music.
6. To appoint a member of the committee to serve with the corresponding member of the NHPEC in each activity as assigned in Part I, Article 5, Item 1.
7. At all exhibitions, space must be reserved for all persons wearing the official badge.
8. Secure suitable reserved seats during all competitions and exhibitions for invited guests, National Officials and Judges.
9. Whenever possible present individual awards immediately after events are concluded and at the site of the event. A dignified ceremony should be arranged to present the Society Honors and Awards.

**ARTICLE 10
THE LOCAL FINANCE COMMITTEE**

1. The Local Finance Committee has charge of the finances of a Festival.
2. Shortly after its appointment, it shall submit to the Local Festival Committee and the National Executive Committee for approval, a contract and budget of estimated income and expenses based on the scope of the Festival as determined by local ideals, and by the demand of the work to be accomplished as prescribed by the rules governing National Festivals.

3. The National Executive Committee shall approve submitted contract and budget under the above provisions. The published financial reports of former Festivals can be guides relative to general expenditures and income.
4. The Finance Committee shall submit to the Festival Committee:
 - a) Ways and means for financing the Festival
 - b) Rules for the collection and deposit of funds
 - c) Rules for the disbursement of funds
 - d) A schedule of expenses pertaining to the Festival
5. After the close of a Festival, the committee shall publish a report of income and expenditures for the Festival in Turner Topics and in the annual report to the National Council.

**ARTICLE 11
THE LOCAL COMMITTEE FOR HOUSING AND ENTERTAINMENT,
(DECORATIONS, FOOD, FESTIVAL BANQUET AND PARADE)**

The duties of this Committee are:

1. It is the duty of this Committee to help Society participants, judges, officials and boosters find suitable housing accommodations.
2. This Committee shall recommend and secure group rates at suitable hotels, motels, dormitories and camp sites.
3. A list of accommodations with rates shall be published in ample time prior to the Festival.
4. A headquarters shall be set up where all pertinent communications shall be posted. An Information Bureau shall be in continuous operation at the headquarters.
5. To arrange a suitable decoration of the Turner building(s), area of competition, larger lodging sites (lobby) and the banquet hall.
6. To conduct the parade, if feasible, complying with local civil regulations. (see Part II, Article 4, Item 2)
7. To arrange for entertainment and suitable outings, but not to conflict with the physical activities scheduled.
8. To arrange for Festival banquet site, caterers, guest speakers, etc.

**PART II
GENERAL REGULATIONS**

**ARTICLE 1
REGISTRATION OF CONTESTANTS**

1. All Athletic contestants must be registered on Official Entry Forms.
 - a) A registration fee will be due from all competitors who register at least 45 days prior to the opening of the Festival.
 - b) A late fee will be charged for entries received and accepted between 44 to 35 days prior to the opening of the Festival. The late fee shall be \$20.00 per competitor.

- c) Entry forms received less than 35 days prior to the festival will **NOT BE ACCEPTED**. (In order to purchase the correct number of awards we must strictly enforce this rule.)
- d) The age of the competitor is determined by what the age is on the 1st day of the National Festival.

Cultural Education entries shall also be registered on Official Entry Forms with the Local Festival Cultural Committee in accordance with National Cultural Committee rules, however the Cultural forms must be mailed per the instructions on the form and received not less than 45 days prior to the opening of the Festival. The Cultural Form must be mailed with the Official Individual Entry Form.

Any Instructor/Coach/Leader, who is in charge of a Society's classes, and is a member of said Society, is eligible to compete.

- 2. All active participants will be charged the entry fee set by the NHPEC and will receive the official badge, free of charge. The Local Committee will furnish the badges, however, the National Council will pay the Local Festival Committee the cost of the badges issued to Officials and competitors out of the Festival Fund of the American Turners. Badges for competitors of Societies shall be delivered to Societies Instructors or Leaders at time of registration. The Entry Fee set by the NHPEC shall accompany the Entry Form.

Turner boosters and other guests will be required to purchase the badge from the Local Festival Committee.

- 3. The official badge shall entitle the owner to free admission to the Festival sites, as well as to all other entertainment in connection with the Festival, except the Festival Banquet and admission-charged tours, but not to specially reserved sections.
- 4. No contestants at National Festivals shall be permitted to participate until a signed release form is presented. Forms for this purpose shall be provided by the NHPEC, and shall accompany the entry forms, which are mailed in advance by the Local Festival Committee. The Local Festival Committee shall enforce this requirement at the time of registration.
- 5. Societies are urged to protect all contestants and members traveling to the Festival under special group insurance.

ARTICLE 2 REQUIREMENTS FOR COMPETITORS

- 1. Contestants taking part in Society team and individual competitions that earn Society points, are not required to perform the Society free exercise routine.
 - a) All Societies performing in the Society free exercise for points must be represented in the Closing Ceremony Mass Drill or points earned from Society Free Exercise will be withheld.
- 2. Participants who violate any of the rules governing competition shall be warned by the judges, and if without results, shall be disqualified from further participation in the contests by the Chairperson of the NHPEC. The disqualified participant's points will be deducted from his/her Society's point total. Any awards previously earned by such disqualified contestant shall be withdrawn and awarded to the next contestant in line for same.
- 3. Contestants who try to gain advantage by unfair means shall be disqualified from further competition during the Festival, upon the decision of the NHPEC. They may be barred from competition at future National Festivals upon the decision of the National Council.

4. Competitors, if eligible for membership in their Societies, must be a member in good standing, with a membership number issued by the National Office, prior to the Festival registration deadline. All other contestants must be either a spouse of a card carrying member, a child of a card carrying member under the age of eighteen (18) or a Youth Member for 90 days or more. All competitors in any American Turners National competition must present their membership card at the tournament site.

Pursuant to the 2008 National Convention, it is acceptable for a child under the age of 18 to participate in Turner National events (physical and cultural competition) even if their parents are not members. However, that child must be a paying enrolled student of a Turner society for at least 90 days prior to the National event and show proof of same. There will be an extra fee for a non-member (child under the age of 18) to compete at the National event. All adults must still be a Turner member in order to participate at a National event.

NOTE: Visiting Turners (non-American) desiring to participate in the American Turners National Festival must be approved by the NHPEC at least 60 days prior to the event. All guests must be sponsored by an American Turner who will accept the responsibility for payment of all required advanced fees and for the conduct of their guests at the event.

5. Participants who absent themselves from their group or squad before an event is closed, shall not be allowed to make up that event. An event completed will not be reopened.
6. If two or more events are scheduled to be competed at the same time, a competitor can only participate in one, and must indicate in advance the event he/she wishes to take part in.
7. Failure on the part of individuals or teams to report on scheduled time for an activity forfeits their right to compete in that event, unless an exception (due to extenuating circumstances) is granted by the NHPEC Chairperson.
8. In case of inclement weather, contestants shall report according to work plan or schedule, and await the decision of the Chairperson of the Local Technical Committee.
9. It is permissible for a competitor to compete in a lower age group, providing it does not result in an unfair advantage. For instance, a man or woman 30 years of age and older can compete with the Active (18-23) (24-29) age group. If he/she makes this choice, he/she must be confined to compete in all competitive events as Active only. He/she cannot compete in any Senior events.
 - a) It is not permitted for a competitor to compete in a higher age group. A man or woman 29 years of age CANNOT compete as a Senior.
 - b) A competitor 18 years of age or older CANNOT compete as a Junior. A competitor in ages 7 through 17 can only compete in their respective age group. (Exception- if there is no competition for any age group, the individual may move up to the next age level with approval from the NHPEC Chairperson.)
 - c) Any infraction of the Festival Rules (written excuse from the Chairperson of the NHPEC excepted), will bar a competitor from taking part in any competition whatsoever.
 - d) The above rules do not apply to Volleyball. Refer to page 25 for complete Volleyball rules.

ARTICLE 3 UNIFORMS

1. Uniform for participants in Society Free Exercise will be designated six (6) months before the Festival by the Local Festival Technical Committee, with the approval of the NHPEC. These must be worn during the above-named activity.
2. For the Model Drill Exercises, apparatus work, track and field and Special Games competitors shall wear the uniform appropriate to the activity.
3. The starting uniform shall display an emblem of Turner recognition (the American Turner emblem or the official emblem of the Festival).
4. Women and girls of all ages participating in Gymnastics are required to wear a leotard. An alternative uniform for Sr. Women is shorts (that end above the knee) and t-shirt. Any shirt worn with shorts must be tucked into the shorts. Shorts (ending above the knee) may also be worn over a leotard. Absolutely no long pants are allowed.

**ARTICLE 4
PARADE**

1. If feasible, a parade shall be held on the first day of the Festival.
2. The parade is to be formed and regulated by the Local Festival Committee.

**ARTICLE 5
FIELD REGULATIONS**

1. The following persons shall be permitted on the floor or field during competition:
 - a) Officials, including all event personnel
 - b) Competitors and their Coaches/Instructors
 - c) Necessary spotters (on Apparatus)
2. It shall be the duty of every competing Society to cooperate in the conduct of the different events by keeping its team and classes in orderly groups, with special emphasis on keeping competitive areas clear of non-contestants. Enforcement of this rule is the responsibility of the Local Festival Committee and appointed event supervisors.
3. Behavior of competitors in the Youth and Junior divisions (7-17), during competition, are the responsibility of their coach or instructor. All competitors ages 7-17 **MUST** have a coach present at each gymnastic event. All competitors ages 7-13 **MUST** have adult supervision from their Society at all track & field and swimming events.

**ARTICLE 6
HONORS AND AWARDS**

1. The distribution of team and Society honors and awards should be an impressive ceremony. It is the duty of the Local Festival Awards Committee, in conjunction with the NHPEC, to make such arrangements that this event shall be a fitting climax to a National Festival.

LIST OF AWARDS

Awards shall be given for the following types of competition:

2. Physical Competition
 - a) Society awards:

- (1) Awards will be based on total points earned by men and women in the Senior, Active, Junior, and Youth groups in all competitive categories that earn Society points.
 - (2) Awards will be presented to the first three places in each society group. Each Society is placed in one of three groups as determined by the Society's total membership of the year prior to the Festival, including honorary and military.
 - (3) After placing all Societies in order according to total membership, then divide the total number of participating Societies by three (3) to determine the groups.
- b) Team Awards:
- (1) Volleyball trophies are to be awarded to the winning Society teams of the first three places in volleyball competition for all five divisions regardless of Society. A minimum of two teams must compete per division to award trophies.
 - (2) Society Free Exercise trophies or plaques will be presented to the Society teams placing 1st, 2nd, or 3rd place.
 - (3) Plaques (5x7) will be awarded for Relays and presented to the winning (first place) running and swimming relay teams in Youth, Junior, Active and Senior (men and women) divisions of competition, regardless of Society group. Societies are limited to one relay team entry in each division of competition.
 - (4) All members of a Team or Relay shall receive a ribbon corresponding to the place their Team or Relay won.
- c) Individual Competition:
- (1) Awards are to be presented to men and women in the Seniors, Actives, Juniors, and Youth age groups.
 - (2) Ribbons shall be presented for individual Gymnastic, Track & Field and Swimming events – 1st through 10th place for Youth, Jr. and Active groups, and 1st through 6th place for all Sr. age groups.
 - (3) Medal awards for All Around Gymnastics and All Around Track & Field – 1st through 10th place. (NOTE: There will be no COMBINED ALL AROUND for Gymnastics and Track & Field as in previous Festivals.) 1st place-gold, 2nd place-silver, 3rd place-bronze, 4th-10th a different color medal.
 - (4) Ribbons will be presented for Special Individual Events and Special Games – 1st through 3rd place.
 - (5) The NHPEC can create additional individual awards as circumstances may require. These awards shall be ribbons.
 - (6) Whenever possible, medals and ribbons won by individuals shall be awarded immediately after the competition at which the honors were won. However, it is suggested that Sr. Track & Field awards be presented at a later time at the Turner Hall.

3. Special Honor Awards

- a) Men and women who have participated as competitors (Physical and /or Cultural), judges (including instructors and event supervisors), or official Turner members of Local Festival Committee, shall be eligible to receive a Special Honor Award at the completion of each fourth (4th) National Festival thus attended. Final determination of eligibility shall rest with the Chairperson of the NHPEC in conjunction with the records at the National American Turner office.
- b) Society secretaries shall submit names of Turners who qualify, to the National Secretary of the American Turners on the designated form, not less than sixty (60) days prior to the opening day of the Festival. After verification, names of Turners duly qualified should be forwarded to the National Office. Applications for the award will not be accepted at the

Festival. Participation at the current Festival may be counted as the fourth (4th), eight (8th) twelfth (12th), or more Festivals attended, for the purposes for receiving the award.

- c) The award shall be in the form of a lapel pin, bearing the National Turner emblem, encircled with the words “NATIONAL FESTIVAL (and) HONOR AWARD”, but excluding the “Leaders in Physical Education since 1848” edition. It shall be approximately the size of the U.S. quarter and include engraving space at the center bottom for the digits, (4, 8, 12,etc.). The fourth (4th) Festival award shall be struck in bronze tone, the eight (8th) in silver tone and the twelfth (12th) and beyond shall be in ten (10) karat gold plate.
- d) Turners who participated in more than twelve (12) Festivals shall receive a special award of the same design in 10K gold plate, bearing the total number of Festivals attended.
- e) The National Office of the American Turners shall be responsible for the documentation, procurement, engraving and shipment of these Special Honor Awards to the appropriate Local National Festival Committee Chairperson for suitable awarding to the recipients.
- f) These awards shall be presented at the Festival Banquet by the National President or his/her designee.

**ALTERATIONS AND AMENDMENTS RELATIVE TO THESE
RULES AND REGULATIONS GOVERNING NATIONAL FESTIVALS**

1. Alterations and changes for the improvement of the National Festival Regulations, which are recommended by the NHPEC, Society Instructors and District Conventions, are to be conveyed to the NHPEC one year prior to a National Festival for inspection, classification and approval.
2. The NHPEC is empowered by the National Council to make sure emergency-type, but feasible rule changes or modifications as are deemed necessary, but not later than six (6) months prior to a National Festival. It is understood that under certain circumstances emergency changes are needed.

**PART III
RULES FOR SOCIETY AND INDIVIDUAL COMPETITION
OF THE AMERICAN TURNERS**

**SECTION 1 – UNIT 1
DETAILS RELATIVE TO SOCIETY COMPETITION**

1. Societies taking part in Society competition shall be divided into three groups based upon Society membership of the year prior to the Festival.
2. One participation point will be awarded to any individual completing all four gymnastic events; One participation point will be awarded to any individual completing all four required Track & Field events (3 events for Youth ages 7-9); One participation point will be awarded to any individual completing a minimum of three swimming/diving events; One participation point will be awarded to any individual participating on a Volleyball team. One participation point will be awarded to any individual for competing in the 1-day or 3-day National Golf Tournament and one participation point will be awarded to any individual competing in the National Softball Tournament when held in conjunction with the National Festival.
3. To decide the place of the Societies in each group, the combined points achieved by Senior men and women, Active men and women, Junior boys and girls, Youth boys and girls shall be totaled.
4. Listed are the activities for Senior men and women, Active men and women, Junior boys and girls and Youth boys and girls.
 - a) Marching Drill and Society Free Exercise
 - b) Gymnastics (Apparatus)

- c) Track & Field
 - d) Volleyball (Excluding both Youth groups)
 - e) Special Individual events
 - f) Special Recreational Games (no Society points)
 - g) Model Drill
 - h) Swimming
5. Before each Festival a schedule of physical activities shall be prepared by the NHPEC in consultation with the Local Technical Committee.

**SECTION I – UNIT 2
MODEL DRILL**

1. A Society may present only one Model Drill.
2. A Society may present a Model Drill comprised of members of any of its competing classes, with a minimum of 6 members.
3. A maximum time of 10 minutes will be permitted.
4. The maximum number of points that can be earned in performing the Model Drill is sixty (60). Three (3) judges will score up to sixty (60) points, and the judges scores will then be averaged for the final score.
5. Each judge shall score the drills as follows:
 - A. Correctness Of Execution: Form (toes pointed, legs straight, etc.), Rhythm , Sureness/Errors= 15 points
 - B. Difficulty: Stunting/Tumbling, Dance, Combination of Movements = 15 points
 - C. Group Action/Presentation: Togetherness, Interaction = 10 points
 - D. Originality: Movements and Combinations, Costumes and Make-up, Presentation of Theme = 15 points
 - E. Crowd Appeal = 5 points
6. Each Society is responsible for providing their own music. The music selection must be approved by the NHPEC.

**SECTION I – UNIT 3
MARCHING DRILL AND SOCIETY FREE EXERCISE**

1. Each Society has the option (but is not required) to enter this competition.
2. These exercises to be performed as a Society group consisting of all ages of men and women, with the minimum of six (6) participants.
 - a) Any Society having less than six(6) participants wishing to perform the Free Exercise may join with another Society to earn their Society points.(See #7 for point distribution)
3. Music and exercises will be distributed by the Local Technical Committee at least nine (9) months in advance of the Festival. Instructors may not count for, or prompt their group. The Local Festival Committee will provide sound equipment for Festival Competition.

4. The maximum number of points that can be earned in performing these exercises is sixty (60), a total of three judges' scores. Each judge can score up to twenty (20) points.
5. Each judge shall score the drills as follows:
 - a) Marching Drill - up to three (3) points.
 - b) Complete performance (omissions, deviations, etc.) of the Society Free Exercise - up to ten (10) points.
 - c) Beauty of the Free Exercise (grace, vigor sureness, rhythm) - up to seven (7) points.
6. These exercises and music shall be prepared by the NHPEC Committee and distributed to the Local Technique Committee one (1) year prior to the Festival.
7. The judging of the Marching Drill and Society Free Exercise shall be done without consultation by three (3) judges whose scores shall be totaled to score up to sixty (60) points. The total points will establish a prime score to be allotted to each Society according to the number of participants in the Society group as follows:

6 contestants or more	= 100%	3 contestants	= 50%
5 contestants	= 83%	2 contestants	= 33%
4 contestants	= 66%	1 contestant	= 17%
8. At some time during the National Festival the Marching Drill and Society Free Exercise shall be performed as a Mass Exercise. An opportune time would be as a part of the Closing Ceremonies of the Festival. Societies participating for points in the Society Free Exercise must be represented at the Mass Exercise during the Closing Ceremony.
9. The Mass Exercise Exhibition shall be conducted by the Festival Leaders. See Part I, Article 3.

**SECTION I – UNIT 4
GYMNASTIC EVENTS (APPARATUS)**

General Information:

1. All Equipment used will meet the regulation USAG specifications unless otherwise stated by the NHPEC six(6) months prior to the Festival.
2. Where applicable, the USAG code of points shall govern this activity.
3. Certified Judges shall judge all levels and grades in gymnastic competitions for Youth, Junior and Active. Qualified Judges may judge Senior gymnastics, however using USAG judges is encouraged.

Active Men, Junior Boys and Youth Boys

1. Apparatus events are to be established for each Festival by the NHPEC. Of the following events perform routines on any four (4), constituting the Gymnastic All Around. Routines will be compulsory or optional based on the USAG Level competing.

a) Horizontal Bar	d) Floor Exercise
b) Parallel Bars	e) Vault
c) Pommel Horse/Mushroom	f) Still Rings
2. The levels of difficulty shall follow the USAG Jr. Olympic competitive program. (Levels 4-10) Youth age (7-9) cannot compete in the Levels 9 or 10.
3. The score per event will follow USAG scoring/judging rules. Each age group, within each level, must have a minimum of 2 competitors registered.

Active Women, Junior Girls and Youth Girls

1. Apparatus events are to be established for each Festival by the NHPEC. Of the following events perform routines on each constituting the Gymnastic All Around. Routines will be compulsory for USAG Levels 3, 4 & 5; and optional for all Xcel Levels.
 - a) Balance Beam
 - b) Floor Exercise
 - c) Uneven Parallel Bars
 - d) Vault
2. There shall be two (2) divisions of competition: 1) USAG Jr. Olympic Program - Levels 3, 4 and 5; 2) USAG Xcel Program - Bronze, Silver, Gold, Platinum and Diamond. Youth age 7 cannot compete in Platinum or Diamond and Youth ages 8 & 9 cannot compete in Diamond.
3. The maximum score per event will be ten (10) points. Each age group, within each level, must have a minimum of 2 competitors registered.

Senior Men

1. Apparatus events are to be established for each Festival by the NHPEC. Of the following events perform optional exercises on any four (4), constituting the Gymnastic All-Around for ages 30+:
 - a) Horizontal Bar
 - b) Parallel Bars
 - c) Pommel Horse
 - d) Floor Exercise
 - e) Vault
 - f) Still Rings
 - g) Two different routines may be performed on ONE event (60+ only)
2. There shall be competitive age groups: 30-39, 40-49, 50-59, 60-64, 65-69, 70-74, 75-79, 80+.
 - a) There shall be one grade of difficulty for each age group.
 - b) Apparatus dimensions shall be announced and included in the Festival program announcement.
 - c) The maximum score for Senior Men, per event, will be ten (10) points.
3. Sr. Men (30-59) must have a minimum of 2 competitors registered, or will be moved down to the next age group. Sr. Men (60+) will remain in their age groups regardless of number of competitors registered.

Senior Women

1. Apparatus events are to be established for each Festival by the NHPEC. Of the following events perform optional exercises on any four (4), constituting the Gymnastic All-Around for ages 30+:
 - a) Balance Beam (Low or High)
 - b) Parallel Bars (40+)
 - c) Pommel Horse (40+)
 - d) Floor Exercise
 - e) Uneven Bars
 - f) Vault
 - g) Rhythmic gymnastics (only ONE routine, with a maximum time of 1 minute) (60+ only)
2. There shall be competitive age groups: 30-39, 40-49, 50-59, 60-64, 65-69, 70-74, 75-79, 80+.
 - a) There shall be one grade of difficulty for each age group.
 - b) Apparatus dimensions shall be announced and included in the Festival program announcement.
 - c) The maximum score for Senior Women, per event, will be ten (10) points.
3. Sr. Women (30-59) must have a minimum of 2 competitors registered, or will be moved down to the next age group. Sr. Women (60+) will remain in their age groups regardless of number of competitors registered.

**SECTION I – UNIT 5
TRACK AND FIELD EVENTS**

General Information

1. National AAU rules shall govern all athletic activities, except as amended by the NHPEC.
2. For new events the NHPEC shall publish details regarding same prior to the next Festival.
3. At all field events, two or more judges shall officiate, making measurements, timing races, etc.; a clerk shall record the results on the proper form.
4. The Track and Field results are to be credited according to the rules and standards.
5. The measuring tapes shall be metric.
6. The Track and Field facilities shall meet acceptable standards. The track surface shall be smooth and marked in lanes; the pits and approach lanes are to be prepared for safe competition.
7. Measurement
 - a) All jumping events shall be measured to the nearest centimeter, falling within the distances actually jumped.
 - b) All timed events are to be recorded to the nearest complete one-hundredth (1/100) of a second
 - c) Shot put events shall be measured to the nearest centimeter, falling within the distance actually attained.
 - d) Throwing events are to be measured to within the nearest centimeter, falling within the distance actually attained.
8. In all events, either judge is responsible for seeing that the event is correctly executed, and for declaring a foul when necessary.

Active Men, Junior Boys, Youth Boys

1. The program for each Festival to be set by the NHPEC.
 - a) The program is to consist of four events including running, jumping and throwing. You are required to do the run, at least one jump and at least one throw.
 - b) Suggested events are as follows and constitute the Track & Field All Around;

100 meter Dash	Standing Long Jump
Running Long Jump	Hurl Ball
Shot Put (16 lbs. Active; 12 lbs. Jr.; 8 lbs. Youth 10-13)	
 - c) Youth (7-9) must compete in 50 meter Dash, Standing Long Jump and Softball Distance Throw. Only those three events are allowed and will be considered Track & Field All-Around for ages 7-9.

Active Women, Junior Girls, Youth Girls

1. The program for each Festival to be set by the NHPEC.
 - a) The program is to consist of four events including running, jumping and throwing. You are required to do the run, at least one jump and at least one throw.
 - b) Suggested events are as follows and constitute the Track & Field All Around:

100 meter Dash	Standing Long Jump
Running Long Jump	Hurl Ball

Shot Put (8 lbs. Jr. & Active, 6 lbs. Youth 10-13)

- c) Youth (7-9) must compete in 50 meter Dash, Standing Long Jump and Softball Distance Throw. Only those three events are allowed and will be considered Track & Field All-Around for ages 7-9.

Senior Men

- 1. The program for each Festival to be set by the NHPEC.
 - a) Seniors will compete in age groups: 30-39, 40-49, 50-59, 60-64, 65-69, 70-74, 75-79 and 80-up.
 - b) Sr. Men (30-59) must have a minimum of 2 competitors registered, or will be moved down to the next age group. Sr. Men (60+) will remain in their age groups regardless of number of competitors registered.
 - c) The NHPEC should consider the age group of the competitors when setting a program for seniors.
 - d) Suggested events are as follows and constitute the Track & Field All Around. Choose 4 of the 6 events including a run/walk, a jump and a throw.
 - 50 meter Dash (30-39), 50 meter Run/Walk (40-up), Standing Long Jump,
 - Hurl Ball, Softball Distance Throw (30+), Shot Put (12 lbs. 30-59; 8 lbs. 60+)

Senior Women

- 1. The program for each Festival to be set by the NHPEC.
 - a) Seniors will compete in age groups: 30-39, 40-49, 50-59, 60-64, 65-69, 70-74, 75-79 and 80-up.
 - b) Sr. Women (30-59) must have a minimum of 2 competitors registered, or will be moved down to the next age group. Sr. Women (60+) will remain in their age groups regardless of number of competitors registered.
 - c) The NHPEC should consider the age group of the competitors when setting a program for seniors.
 - d) Suggested events are as follows and constitute the Track & Field All Around. Choose 4 of the 6 events including a run/walk, a jump and a throw.
 - 50 meter Dash (30-39), 50 meter Run/Walk (40-up), Standing Long Jump,
 - Hurl Ball, Softball Distance Throw (30+), Shot Put (8 lbs. 30-59; 6 lbs 60+)

**SECTION I – UNIT 6
SWIMMING and DIVING**

- 1. The rules of the current AAU swimming guide shall govern all competition in these events, except where noted in the National Festival rules. The swimmer must be able to swim the required distance without stopping and by using proper technique.
- 2. There shall be five (5) swimming events for Jr. and Active Men and Women, and three (3) events for Senior Men, Senior Women, and Youth.
- 3. All swimming events will be run against time, therefore age groups of same distance and stroke may be run together, no matter what gender. There will be no preliminary events.
- 4. The NHPEC will announce the type and length of pool to be available at least six (6) months prior to the date of competition.
- 5. Events for pools 25 meters in length:

YOUTH BOYS & GIRLS (7-9, 10-13) and
SENIOR MEN & WOMEN (30-39, 40-49, 50-59, 60-64, 65-69, 70-74, 75-79, 80+)

25 m Free Style
25 m Breast Stroke
25 m Back Stroke

JR. BOYS & GIRLS (14-17) and
ACTIVE MEN & WOMEN (18-23, 24-29)

50 m Free Style
100 m Free Style
50 m Breast Stroke
50 m Back Stroke
50 m Butterfly

6. Each contestant may enter any three (3) individual events (from lists above) and both relays (Special events).
NOTE: Three (3) events shall be interpreted as any three (3) swimming events, or two (2) swimming events and diving.
7. Sr. Men and Women (30-59) must have a minimum of 2 competitors registered, or will be moved down to the next age group. Sr. Men and Women (60+) will remain in their age groups regardless of number of competitors registered.
8. DIVING
 - a) There shall be two (2) compulsory and one (1) optional dives by participants competing in age groups identical to those for swimming competitions.
 - b) All dives will be performed from a one (1) meter board.
 - c) The compulsory dives will be: #101 – front dives and #201 – back dives.
 - d) The optional dive must be different from the compulsory dives

**SECTION I – UNIT 7
VOLLEYBALL**

At American Turner Festivals the volleyball competition shall be indoor volleyball as governed by USA Volleyball rules (with the following modifications), with the provision that the NHPEC in cooperation with the Local Technical Committee may make changes to suit local conditions. When possible, Festival competition will be in the form of a round robin followed by single elimination if time and facilities permit.

1. Societies are required to submit a roster form with a maximum of 15 players for each team being entered.
2. Permit teams to participate with only five (5) players and in the event of injury(s), a team may continue with a minimum of four (4) players (open position(s) to be center back (and left back if also needed)).
3. The team uniform shall be matching shirts with numbers for each player. Libero shirts must be contrasting color.
4. In men's competition women may be part of the team.

5. Divide men's competition into 2 divisions – Actives+ (All ages - 14 & up – using a 7' 11 5/8" net height) and Seniors (55+ - using a 7' 9 5/8" net height). Divide the women's competition into 3 divisions – Juniors (11-17) and Actives+ (14+) – both using a 7' 4 1/8" net height, and Seniors (50+) - using 7' 2 1/8" net height.

NOTE: It is permissible for a person to play in more than one division.

Examples: A 55 year old man can play in the Actives+ division AND the Seniors (55+) division, as long as the two divisions do not overlap court time. A 45 year old woman may play on the Men's Active+ division AND in the Women's Active+ division.

In addition to the above divisions, a **Co-ed** competition will have 3 divisions: 11-17, 18+ and a Senior Division (50+ for women and 55+ for men). Both the 11-17 and 18+ divisions will use a 7' 11 5/8" net height and the Senior Co-ed division will use a 7' 9 5/8" net height. Each team must have a minimum of 2 male and 2 female players on the court and all players must rotate positions.

6. For Turner Societies unable to field a team, teams composed of players from 2 or more Societies may be formed with permission of the NHPE Chairperson or the National Volleyball Coordinator. (District teams should be formed first, then conglomerate teams) This is to permit individuals from Societies having low numbers of Festival participants to participate in volleyball. (However, individual players may play on only one team per division.)
7. USA Volleyball rules govern all situations not covered by the above. This includes - rally scoring in all games with 2 point difference required to win a game (except where indicated otherwise), Libero player may be used in any competition, unlimited individual substitution (12 max team subs) permitted, and a let service is a good. (Exception: "continuous" rotation using 7 or 8 players may be used – if requested in advance and followed throughout an entire game.)
8. Society points will be awarded in each of the 8 "divisions" as follows:
 - a) 1st – 60 pts, 2nd – 54 pts, 3rd – 48 pts, (etc – decreasing 6 points per place),
 - b) If less than 6 players on a team, then points reduced accordingly, and
 - c) If a team has players from several Societies, the Society points for that team will be prorated among the Societies, according to each Societies' percent of participation.
9. A Society may enter more than one team per division.
10. Volleyball Formats:
 - a) 2 teams in a division: It is recommended having one match; best 3 out of 5; 25 point rally scoring games 1-4 (and 15 points for the 5th game if needed).
 - b) 3 teams in a division: Pool play; One 25 point rally scoring, no cap; 30 minute time limit game per match; 3 matches in pool play, followed by playoff where 3rd vs 2nd in best 2 of 3 (21, 21, 15) followed by winner vs 1st in best 2 of 3 (21, 21, 15 if needed). (approx. 3 - 3 ½ hours)
 - c) 4 teams in a division: Pool play; round robin; One 25 point rally scoring, no cap; 30 minute time limit game per match. 6 matches in pool play (on 2 courts), followed by playoff where 3rd vs 2nd and 4th vs 1st in best 2 of 3 (21, 21, 15), followed by winners playing for 1st and 2nd in best 2 of 3 (21, 21, 15 if needed) and losers playing in consolation match for 3rd and 4th (One 25 point no cap game). (approx 3 ½ - 4 hours)
 - d) 5 teams in a division: Pool play; full round robin (10 matches) on 2 courts; One 25 point rally scoring, 27 point cap; 25 minute time limit on the pool play matches. Play offs limited to top 4 teams with 1st vs 2nd for 1st & 2nd place and 3rd vs 4th for 3rd & 4th place (both best 2 of 3, all 15 points, 17 cap on first two, no cap on deciding game). (3 ½ - 4 hours)
 - e) 6 teams in a division: It is recommended dividing into 2 pools of 3 teams each and playing a mini round robin within each pool; One 30 point rally scoring game to constitute a match, between each of the 3 teams within each pool, to be followed by a playoff between the pools where pool A 3rd place plays pool B 2nd place (and B2 vs A3) followed by A1 playing winner of

the 1st match and B1 playing winner of M2. These are followed by winners of M3 and M4 playing for 1st and 2nd place and losers playing for 3rd and 4th place. All of the playoff matches could be best 2 of 3; 15 point rally scoring games. If a 30 minute time limit is imposed on pool play matches, the total time would be approximately 3 -3 ½ hours.

- f) 7 teams in a division: Pool play only. Full round robin (21 matches); needs 3 courts; One 30 point rally scoring game per match (30 minute time limit but must win by 2 points). No playoffs, except in case of ties for 1st, 2nd and/or 3rd places, which requires one 15 point game to decide final position. (approx. 3 ½ - 4 hours)
 - g) 1 team in a division: No play, or possibly have exhibition match(es) with closest similar division.
 - h) Tie Breaking:
 - 1. Where all tied teams can still advance to 1st place. Use results of head to head match(es) to determine playoff position. If 3 way tie, then use total differential scores. If still tied then flip coin.
 - 2. Where lesser of teams would be excluded from playoffs or advance to higher position. A single 15 point game (no cap) to break two-way tie.
 - 3. Projected times stated above excludes additional 20 minutes per 15 point tie breaker.
11. For assistance in finding players or teams, contact the National Volleyball Coordinator at philklabvb@comcast.net.

SECTION I – UNIT 8 SPECIAL EVENTS

General Information

1. There will be competition offered in special events, as determined by the NHPEC for each Festival. Suggested events are:
 - a) Tumbling
 - b) Rhythmic Gymnastics
 - c) 5 kilometer Run
 - d) 1500 meter Run (14-29)
 - e) 800 meter Run (10-13 & 30-59)
 - f) 400 meter Run (60+)
 - g) Swimming Relays
 - h) Running Relays
 - i) Golf
2. A minimum of six (6) entries per event must be received in advance of the Festival, in order to conduct a special event. This minimum requirement may be reduced by agreement between the Chairperson of the NHPEC and the Local Technical Committee.
Notice of Special Event cancellations shall be forwarded to Societies concerned as soon as possible after the Festival entry deadline has passed.

The NHPEC shall name the events to be competed and is authorized to add events to those named, of which, however, only two (2) may be introduced at any Festival. These events shall be published six (6) months prior to the date of the Festival.

Guide for Special Events

3. TUMBLING
 - a) A spring strip mat of 60 feet by 6 feet and 4 inches thick (approx.) dimensions shall be provided. If not available, a spring floor exercise mat may be used. The Local Technical

Committee shall include the type of equipment available for this event at least six (6) months prior to the competition.

- b) One optional routine consisting of three (3) passes, one primarily backward, one primarily forward, and one primarily mixed sequence with one flight element per pass shall constitute a complete routine.
- c) The rules found at USAT1.com shall govern this event, which shall be judged by two qualified judges on the basis of one (1) to ten (10) points.
- d) Age groupings as follows: 7-13, 14-29 and 30+

4. RHYTHMIC GYMNASTICS

- a) When Rhythmic gymnastics is included in the Festival program, information concerning competition will be included in the Festival Supplemental Handbook.
- b) Age groups shall be 7-13, 14-29 and 30+.

5. DISTANCE RUNS

- a) For distance runs – 400 meters (60+), 800 meters (10-13 & 30-59), 1500 meters (14-29) and 5K (10-13, 14-29, 30+), refer to section on rules for Track & Field.
- b) The Special Event Distance Runs shall be done with the Relays after the regular Track & Field events are done.

6. GOLF (rules for one-day tournament)

- a) Each golfer must furnish his/her own equipment, including balls.
- b) There shall be separate tournaments for Men and Women. Separate awards shall be presented.
- c) The game shall be medal play (total score) tournament, no handicap.
- d) Players will be grouped in foursomes as far as possible, and will be started at about five (5) minutes apart.
- e) The tournament shall be played a minimum of eighteen (18) holes.
- f) The players having the lowest medal score for 18 holes shall be declared the individual winner of the Festival Tournament.
- g) In the case of a tie for first place, a sudden death play-off shall decide the winner.
- h) An umpire or referee shall decide on any breach of rules that he/she may observe, whether or not an appeal has been made.
- i) All rules not covered here shall be according to the U.S. Golf Association rules.

****OR****

7. GOLF (rules for three-day tournament)

- a) Each golfer must furnish his/her own equipment, including balls.
- b) Flights will be determined by the Local Festival Committee and the National Golf Chairman, dependent upon the number of entries.
- c) The first two day's scores will determine which flight the golfer will be placed in, and those combined scores will be added to the last day's scores to determine flight winners. There will be a minimum of two winners in each flight.
- d) There should be a maximum of thirty (30) golfers per flight in the Men's Division, except in championship flight. The number shall be determined by the National Golf Chairman.
- e) Senior Men's Division (55+) has a minimum of two flights allowed. If a Senior man wishes to play in the Men's Division, he may do so.
- f) Super Senior Men's Division (65+) has one flight. This Division will only play 9 holes per day. If a Super Senior man wishes to play in the Senior or Men's Division, he may do so.

- g) Women's Division has a minimum of three flights. Number in the Championship flight will be determined by the National Golf Chairman.
- h) Senior Women's Division (55+) has one flight. This Division will only play 9 holes per day. If a Senior lady wished to play in the Women's Division, she may do so.
- i) There will be a team championship composed of four men or four women from the same Society. These members, in each division (Men's, Senior Men's, & Women's only, unless entries in other divisions warrant the addition of additional team trophies) will be determined by the four lowest golfers scores in each division and within a Society at the end of the tournament.
- j) Team trophies for team championships will be a traveling trophy awarded to the Society. Individual trophies can be awarded for team competition.
- k) The medalist trophy should be awarded to the man and woman, senior man, super senior man and senior woman who have the lowest score on the first day of competition.
- l) The Local Festival Committee will designate certain holes for the longest drive and closest to the pin on the first day of competition only. Trophies will be awarded for each division.
- m) All ties will be broken by a sudden death play-off. If this is not possible, the following procedure will apply: in case of ties for medalist, team or flight winners, a regulation deck of playing cards using only the ace through 9 of a black suit and red suit will be shuffled and placed face down. One card will be drawn by a member of the rules committee. This card denotes the hole on which to begin the playoff and working up until the tie has been resolved. (Black cards denote the first nine and red cards denote the second nine.)
- n) There will not be any "gimme" puts. All puts will be holed out.
- o) An umpire or referee shall decide on any breach of rules that he/she may observe, whether or not an appeal has been made.
- p) All rules not covered here shall be according to the U.S. Golf Association rules.
- q) It is suggested that the tournament be held on one golf course if possible.

8. SWIMMING RELAYS

- a) Each Society may enter one (1) men's and one (1) women's relay team in each class of competition, e.g. (7-13 Youth), (14-29 Jrs. & Actives) and (30+ Srs.).
- b) Four Youth boys or four Youth girls (7-13) comprise the 100 m Free Style Relay. Four Jr./Active boys or four Jr./Active girls (14-29) comprise the 200 m Free Style Relay. Four Senior men or four Senior women (30+) comprise the 100 m Free Style Relay.
- c) Three Youth boys or three Youth girls (7-13) comprise the 75 m Medley Relay. Four Jr./Active boys or four Jr./Active girls (14-29) comprise the 100 m Medley Relay. Three Senior men or three Senior women (30+) comprise the 75 Medley Relay.
- d) In all relay races each competitor swims an equal distance. *The over 60 age group may be subdivided into older age divisions if enough participation permits.
- e) A lane is to be provided for each team.
- f) Contestants may compete on both the Medley and Freestyle swimming relay teams.
- g) A minimum of two teams must be entered and ready to compete in each class swimming relay race, in order to hold the competition and receive points and awards.
- h) Contestants registered on the official Entry forms determine the number of available swimmers in any one class or competition. If four (4) or more are listed (entered), those contestants (at least four (4)) must comprise the relay team for that class. E.g Actives may not compete on Junior or Senior teams. Seniors may complete the minimum number (4) on an incomplete Active or Junior relay team. E.g. A Society having two (2) Actives competing, and desiring to enter a relay team may compete by adding only two (2) Seniors to complete a four (4) man/woman team.
- i) When a Society cannot field a relay team, they may combine boys and girls, or men and women on the same relay team provided they are within the same age group. That Society can only

have one team in that age group. This combined relay team can only compete as a boys' or men's team.

- j) 75 m Medley Relay order is as follows: Back stroke, Breast stroke, Freestyle.
- k) In the event that a Society does not have enough swimmers to field a Relay, a District Relay may be formed. A District Relay must be registered prior to the start of the National Festival, following all registration guidelines.

9. RUNNING RELAYS

- a) Each Society may enter one (1) men's and one (1) women's relay team in each class of competition, e.g. (7-13 Youth), (14-29 Jrs. & Actives) and (30+ Srs.).
- b) A 400 meter relay team shall consist of four (4) men, each man to run 100 meters. A 200 meter relay team shall consist of four (4) men, each man to run 50 meters.
- c) The relay shall be straight-a-way (continuous) around the track. The NHPEC may make changes in regard to the number on a team, type of race, or distance, should local conditions warrant same. These shall be made public six (6) months prior to the Festival.
- d) A lane is to be provided for each team. Each team furnishes its own baton.
- e) Contestants may compete in only one (1) running relay.
- f) A minimum of two (2) teams must be entered and ready to compete in each class running relay race, in order to hold the competition and receive points and awards.
- g) Contestants registered in Track and Field on Official Entry forms determine the number of available runners in any one (1) class of competition. If four (4) or more are listed (entered), those contestants (at least four (4)) must comprise the relay team for that class. E.g. Actives may not compete on Junior or Senior teams. Seniors may complete the minimum number (4) on an incomplete Active or Junior relay team. E.g. A Society having two (2) Actives competing, and desiring to enter relay team, must compete by adding only two (2) Senior to complete its four (4) man/woman team
- h) In the event that a Society does not have enough runners to field a Relay, a District Relay may be formed. A District Relay must be registered prior to the start of the National Festival, following all registration guidelines.
- i) The relays shall be run after the regular Track & Field events are completed.

SECTION II METHOD OF ACCOUNTING POINTS FOR SOCIETY, INDIVIDUAL AND SPECIAL EVENTS

Scoring for all Events is as follows:

First place	10 points
Second place . . .	9 points
Third place	8 points
Fourth place . . .	7 points
Fifth place	6 points
Sixth place	5 points
Seventh place . . .	4 points
Eighth place . . .	3 points
Ninth place	2 points
Tenth place	1 point

SECTION II – UNIT 1 GYMNASTIC SCORING

- 1. Upon recommendation of the NHPEC the above scoring table is to be used in tabulating Society

and individual points.

2. To reduce confusion, all routines in all age groups and levels will be judged on a scale of ten (10) points for each exercise, except men ages 7-29 will be judged based on current USAG scoring.
3. For individual points, a gymnast's score for each event is to be totaled and becomes the individual All-Around gymnastic score. This score is to determine individual awards in each of the age groups and levels. The All Around score does not earn Society points.
4. Each individual event for a gymnast that earns 1st thru 10th place shall earn Society points according to the table above.

EXAMPLE: A gymnast scores 8.2 on Beam; 5th place, 8.8 on Bars; 3rd place, 7.1 on Vault; 10th place and 9.0 on Floor; 2nd place. The gymnast's total All-Around Gymnastic score is 33.10, which will determine an All-Around place in her age group and level. This place/score does not earn Society points. However, 5th place earns 6 points, 3rd place earns 8 points, 10th place earns 1 point and 2nd place earns 9 points (according to the table above), for a total of 24 Society points.

A gymnast may compete in only 1 or 2 events and still earn Society points if he/she places in the top ten. However, by not competing in the required amount of events for all-around, the gymnast will not earn the participation point.

SECTION II – UNIT 2 TRACK & FIELD SCORING

1. Upon recommendation of the NHPEC the above scoring table is to be used in tabulating Society and individual points.
2. For individual points the competitor's score for each event is to be totaled and become the All Around Track & Field score. This score is to determine individual awards in each of the age groups. The All Around score does not earn Society points.
3. Each individual event for a competitor that earns 1st thru 10th place shall earn Society points according to the table above.

EXAMPLE: A competitor places 5th in Shot Put, 1st in Standing Long Jump, 2nd in Dash and 5th in Hurl Ball for a total of 31 points (according to the table above). The 31 points is used to determine the All-Around place in the competitor's age group. The competitor has earned 31 Society points.

A competitor may compete in only 1 or 2 events and still earn Society points if he/she places in the top ten. However, by not competing in the required amount of events for all-around, the competitor will not earn the participation point.

SECTION II – UNIT 3 NATIONAL GOLF & NATIONAL SOFTBALL TOURNAMENT SCORING

1. When the National Golf Tournament and/or National Softball Tournament are held in conjunction with the National Festival, all participants for Golf and/or Softball will earn one participation point to be added towards their Society points for the National Festival.
2. Participants for Golf will also earn Society points based on their award received in their tournament, according to the table on page 30.

3. Softball teams will earn Society points based on their place earned as follows: 1st – 60 points, 2nd – 54 points, 3rd – 48 points (etc. – decreasing 6 points per place). If a team has players from several societies, the Society points for that team will be prorated among the Societies according to each Societies' percent of participation.

**SECTION III
RULES GOVERNING INDIVIDUAL COMPETITION**

**SECTION III – UNIT 1
JUMPING EVENTS**

1. **RUNNING LONG JUMP**
 - a) Each contestant shall be allowed three (3) jumps, of which the best shall be recorded.
 - b) The competitor may not cross the edge of the take off board nearest the landing area (pit). An impression made on the ground in front of the take off board constitutes a FOUL and a trial. **NO MEASUREMENT IS TO BE TAKEN.**
 - c) The pit landing must be made with both feet simultaneously. Running through the pit, or landing with feet separately is a FOUL and a trial. **NO MEASUREMENT IS TO BE TAKEN.**
 - d) The jump is measured from the nearest impression in the pit made by any part of the jumper's body to the take off board at a right angle with the length of the board. The tape measure distance is read at the edge of the take off board.
 - e) Three trials must be taken in rotation.
2. **STANDING LONG JUMP**
 - a) The ground in front of the take off board is to be excavated to a depth of 2 inches to permit a toe hold. The board is to be at least 8 inches wide and 2 feet long.
 - b) Both feet must leave the take off board simultaneously and land in the pit simultaneously. If not, the jump is a FOUL and a trial. **NO MEASUREMENT IS TO BE TAKEN.**
 - c) Rules for measuring the running long jump shall also govern the standing long jump. The three (3) trials must be taken consecutively.
3. **STANDING TWO STEP JUMP**
 - a) Three jumps shall be permitted, of which the best one shall count. The jumps may be taken in rotation.
 - b) Rules regarding the take off board in the running long jump shall govern this event. However the distance from the take off board to the pit must be adjusted to suit this event.
 - c) Either foot shall be positioned at the take off point, with the opposite foot swinging free from the take off board. Step or leap forward onto the suspended foot. Step or leap forward onto the take off foot. Step or leap forward from the second step and land in the pit on both feet simultaneously. Sequence from take off is step-step-jump. (EXAMPLE: Left foot take off, right foot landing, left foot landing and jump with both feet landing in pit.)
 - d) Rules for measuring or the same as for the running long jump.

**SECTION III – UNIT 2
THROWING EVENTS**

1. **HURL BALL**
 - a) The ball dimensions shall be as follows:
 - Weight.....3.3 to 3.5 lbs. (1.5 to 1.6Kg)
 - Loop length.....11 inches (28 cm,)
 - Loop width.....1 inch (2.54cm.)

- b) The throw shall be free style from a stand or run, with or without turn.
 - c) Overstepping or stepping on the scratch (throwing) line with any part of the body constitutes a FOUL and a trial. NO MEASUREMENT IS TO BE TAKEN.
 - d) A ball hitting the boundary line on the first ground contact is a valid throw. A ball landing outside the boundary line on the first ground contact is a FOUL and a trial. NO MEASUREMENT IS TO BE TAKEN.
 - e) Three (3) consecutive trials will be taken and the best throw will be recorded. Each throw shall be marked by a judge with a distance marker, and the best throw measured.
 - f) The distance of the throw shall be measured from the nearest impression of the ball's contact to the ground from the center of the throwing line. The field shall be laid out as a wedge with a sixty(60) degree arc extending outward establishing the fair ground area.
2. SOFTBALL (12") DISTANCE THROW
- a) Three consecutive trials shall be permitted. Each throw shall be marked by a judge with a distant marker, and the best throw measured.
 - b) The throw will be free style, with or without a run, from behind a scratch (throwing) line, into a 30 foot wide lane.
 - c) Over stepping or stepping on the scratch (throwing) line with any part of the body constitutes a FOUL and a trial. NO MEASUREMENT IS TO BE TAKEN.
 - d) The distance of the throw shall be measured from the nearest impression of the ball's contact to the ground at a right angle of the scratch (throwing) line. A ball landing outside the boundary line on the first ground contact is a FOUL and a trial. NO MEASUREMENT IS TO BE TAKEN
3. SHOT PUT
- a) A sixteen (16) pound iron shot shall be used for Active Men. A twelve (12) pound iron shot shall be used for Junior Boys and Senior Men (30-59). An eight (8) pound shot shall be used for Youth boys (10-13), Active Women, Senior Women (30-59) and Senior Men (60+). A six (6) pound iron shot shall be used for Youth Girls (10-13) and Senior Women (60+).
 - b) The Put shall take place from within a circle, the inside diameter of which is seven (7) feet (2.13 meters).
 - c) Stepping on the edge of the circle, on top or across the toe board or outside of the circle before the put is marked shall constitute a FOUL and a trial. NO MEASUREMENT IS TO BE TAKEN.
 - d) The Put shall be measured from the nearest impression, back towards the center of the circle, reading the distance to the inner edge of the toe board and recorded.
 - e) Three consecutive Puts shall be permitted, and marked by the judge with distant markers. The longest Put shall be measured and recorded.
 - f) The shot must be held in close proximity to the competitor's chin, and should not be dropped below this position while putting.
 - g) The field shall be laid out as a wedge with a sixty (60) degree arc starting at the center of the seven (7) foot put circle extending outward establishing the fair ground area.

**SECTION III – UNIT 3
RUNNING EVENTS**

1. DASHES, WALK/RUN (100m and 50m)
- a) The track shall be a regulation size track, divided equally into six lanes.
 - b) Experienced timers shall time each runner.
 - c) A qualified, certified starter shall start all races. A second false start by the same runner shall disqualify that competitor. All races must be started with a starter gun or a whistle. (Due to inaccuracy, a drop of the arm or a vocal start is not allowed.)

- d) A Judge shall be designated to observe and detect lane violations. Competitors must remain in his/her assigned lane through the finish line.
 - e) Distance and times are determined by age group.
 - f) Contestants competing in the Walk/Run event may run or jog the entire distance, combine running and walking, or walk only.
2. MIDDLE DISTANCE RUNS (400m, 800m and 1500m)
- a) A qualified starter shall start the race. One experienced timer is needed for the race. Adults are needed to count laps for runners and assist the timer at the end of the race to record the place of runners as they cross the finish line.
 - b) The runners shall start with either a “stagger start” or a “waterfall start”.
 - i. Stagger start has 2 runners per lane starting at the stagger start lines on the track. Runners must stay in their designated lane until completing the 1st turn on the track (approx. 100m). At that point all runners may move to the inside lane. Moving sooner results in a disqualification of that runner.
 - ii. Waterfall start has all runners starting side by side. The start line is on an angle across the lanes. The runner in the outside lane is approximately 2m ahead of the runner on the very inside lane. Runners may move to the inside lane right after the sound of the gun. When moving to the inside lane, tripping another runner shall result in a disqualification.
 - c) When the runners cross the finish line they are to be kept in order until the correct place is recorded for each runner by the Official.
3. FIVE KILOMETER (5K) RUN
- a) The course shall be measured and laid out in an appropriate area, by Local Festival Committee.
 - b) Permission to lay out the course and block traffic, where necessary, shall be obtained from the local Police Department.
 - c) The run shall be scheduled at a time when automobiles and pedestrian traffic is apt to be at a minimum. A suggested time is on a Sunday morning.
 - d) The 5K run will be contested by three (3) groups for Men and three (3) groups for Women. (10-13, 14-29 & 30+) All groups will run in the same race.
 - e) One (1) timer shall relay the runner’s time as he/she crosses the finish line.

**SECTION III – UNIT 4
SPECIAL RECREATIONAL GAMES**

General Rules

1. The following Special Recreational type games are to be placed in open competition:

a) Badminton	c) Handball
b) Tennis	d) Racquetball
2. The above games will be competed, providing facilities are available, and sufficient entries are received to conduct them. In all special games (this does not include volleyball) there must be six (6) contestants or six (6) double teams, as the case may be, entered on the Official Entry forms, received in advance of the Festival. As in Special Events this minimum requirement may be reduced by agreement between the Chairperson of the NHPEC and the Local Technical Chairperson.
3. The NHPEC is authorized to add games to those named, of which only one may be introduced at any Festival.
4. These events shall be published six (6) months prior to the date of the Festival.

5. No Society point will be awarded (See Part II, Article 6 – Honors and Awards). Awards will be ribbons.
6. The rules of the different organizations fostering these games shall govern their conduct. The NHPEC may establish rules to suit local conditions.
7. Separate entry sheets shall be sent out prior to the Festival. Entries are required to be returned with the regular Society entry forms.
8. The Local Technical Committee shall provide proper playing courts and areas according to the official rules.
9. All contestants are required to comply with the regulations printed under Part II, Article 1 (Registration of Contestants) and Article 2 (Requirements of Competitors).
10. Any necessary additional information relative to courts and courses, further rules, time and location changes, etc., will be included with the Festival Entry forms.

BADMINTON

- a) Size of the court and regulation equipment is as specified in the American Badminton Association Rules.
- b) These rules shall govern the competition.
- c) Shuttles and racquets shall be furnished by the competitors.
- d) There shall be singles, doubles and mixed double competition open to all contestants, men and women.

HANDBALL AND RACQUETBALL

- a) The National Handball Association and Racquetball Association rules shall govern the competition.
- b) There shall be singles and doubles open to all contestants, Men and Women.
- c) Each contestant is to furnish his/her own equipment, gloves, racquets and balls.

TENNIS

- a) Courts and equipment are as specified in the U.S. Tennis Association rules. These rules shall govern the competition.
- b) Each contestant is to furnish his/her own equipment, racquets and a can of balls.
- c) There shall be singles competition open to all contestants, Men and Women.

PART IV EQUIPMENT AND FORMS

SECTION I FACILITY, EQUIPMENT AND PERSONNEL REQUIREMENTS

SECTION I – UNIT 1 GYMNASTICS

In all groups of competition –Chalk, First Aid Kit, Score Cards for each event per gymnast, Squad Leaders – one (1) for every twelve (12) gymnasts, P.A. system - necessary to make general announcements.

WOMEN: The ideal situation is to have two (2) of every piece of apparatus. (42'x42' Floor Exercise Mat, Uneven Bars, Balance Beams, Vaulting Horse/Tables and Spring Boards) Enough safety mats and landing mats to surround each piece of apparatus. Warm-up shall be timed on a rotating basis for all events. Stop watches and timers are required at Balance Beams to time routines. A P.A. system shall be provided for music for Floor Exercises. One USAG certified judge for each of the four (4) events in all levels. For Senior competition, one (1) qualified Turner judge is allowed at each event, however it is recommended that USAG certified judges are used.

MEN: The ideal situation is to have two (2) of every piece of apparatus. (42'x42' Floor Exercise Mat, Rings, Parallel Bars, Horizontal Bar, Pommel Horse, Vaulting Horse/Table and Spring Boards) Enough safety mats and landing mats to surround each piece of apparatus. Warm-up shall be timed on a rotating basis for all events. One USAG certified judge for each of the six (6) events in all levels. For Senior competition, one (1) qualified Turner judge is allowed at each event, however it is recommended that USAG certified judges are used.

RHYTHMIC GYMNASTIC REQUIREMENTS

A 42'x42' Floor Exercise Mat, one (1) timer and stop watch, a P.A. system for music and one (1) qualified judge are to be provided. The gymnast is to furnish his/her own rhythmic hand apparatus and music.

SECTION I – UNIT 2 TRACK AND FIELD

OVERALL AT SITE

Plenty of water, cups, ice, first aid equipment, tarp or tent for shade, cot, blanket, sheet. Should have an RN, Dr. or EMT on site. Pencils, score sheets, clipboards and rule sheets for each event.

JUMPING EVENTS – Requirements for each pit.

Standing Long jump, Running Long Jump and Standing Two Step Jump

EQUIPMENT:

Metric measuring tape
Rake
Whisk Broom
Regulation Pit

PERSONNEL:

1 to measure at board
1 to mark from last impression
1 to record distances
1 to rake

HURL BALL

EQUIPMENT:

3 Hurl Balls
3 Markers for landing point
Metric measuring tape
Chalk or something to mark boundary lines

PERSONNEL:

1 to mark impression and measure
1 to measure at starting line
1 to records distances

**Competitors should be in field to retrieve balls after they have competed.

SHOT PUT

Same as Hurl Ball except 16 lb., 12 lb., 8 lb. and 6 lb. Iron Shot

SOFTBALL DISTANCE THROW

Same as Hurl Ball except 3 - 12" Softballs

RUNNING EVENTS – all running events require a starting gun with blanks and a whistle (to be used if gun malfunctions).

DASHES, WALK/RUN

EQUIPMENT:

Starter gun & whistle
4-6 Stop watches
4-6 measured straight lanes

PERSONNEL:

1 to start runners
1 timer per lane with stop watch
1 to record times
1 to watch for foul & lane violations

MIDDLE DISTANCE RUNS (400m, 800m & 1500m)

EQUIPMENT:

400m Track
Starter gun & whistle
1 Stop watch

PERSONNEL:

1 to start runners
1 to watch for fouls & lane violations
1 timer
1 for each runner to count laps
1 to record places/times
2-3 adults at end of race to keep runners in proper order according to finish until recorded

5K RUN

EQUIPMENT:

Properly laid out course
1 Stop watch
Water and cups
Fruit at end of race (preferably oranges)

PERSONNEL:

1 to start runners
1 to judge starting line
1 to record times
4-6 adults at end of race to keep runners in proper order according to finish until recorded
People to man water stops on course and at end

RELAY RACES – team must supply their own baton

EQUIPMENT:

4 Stop watches
4 Lanes marked with exchange zones

PERSONNEL:

1 to start race
1 to judge for fouls & lane violations
1 timer per lane
1 to record times

**SECTION I – UNIT 3
DIVING AND SWIMMING**

DIVING

EQUIPMENT:

One (1) meter diving board
Sound system
Degree of difficulty book
Table and chairs
Numbered flash cards: zero (0) to ten (10) in .5 increments(0.5, 1.5, 2.5 etc.)

PERSONNEL:

Two (2) Judges
Announcer
Two (2) Score keepers

Master score sheet for score keeper

- i. Computer should have each competitor with each of the two (2) compulsory dive/degree of difficulty ___ x score ___ = ___ total.
- ii. Computer should have one optional dive listed, degree of difficulty ___ x score ___ = ___ total.
- iii. The combined total ____.

Awards should be presented in the pool area at the conclusion of the diving competition for each age group.

SWIMMING

EQUIPMENT:

Sound system
Lane markers for the pool
Whistle
Table and chairs
Eight (8) to twelve (12) stop watches
Two (2) starter guns with blank shells
(If available an audible buzzer may be used)

PERSONNEL:

Announcer
Official Starter
Two (2) timers per lane
Judge for lane violations

Awards should be presented in the pool area at the conclusion of the competition.

** Event Supervisor or Assistant should announce each event (swimming and diving). A NHPEC representative should work with the Local Event Supervisor. The Local Event Supervisor is responsible to obtain all necessary workers, equipment, watches, etc. to run the events. He/she should get necessary score sheets, pencils, etc., including awards prior to the events.

SECTION I – UNIT 4 VOLLEYBALL

PERSONNEL:

Tournament Director – Either National VB Coordinator or experienced local host Society VB Chairperson. Responsible for establishing formats for each of the divisions tournaments, providing on site supervision, and assisting in officiating and/or scoring. The Tournament Director is also responsible for reporting results and awarding trophies.

Site Coordinator – Responsible for obtaining site (minimum 2, but possibly 3 or 4 courts). These courts should have a minimum of 6 feet of playing area on both sides and ends of each court with preferably 9 feet behind the courts and 12 foot separation between adjacent courts. There should be 23 feet minimum ceiling height, free from obstructions. Desired minimum dimensions are 85' long by 72' wide with a minimum ceiling height of 23'. This means without fixed basketball backboards. With fixed basketball backboards, there should be at least 80' between the backboards (and at least 65' between fixed crosscourt backboards). The Site coordinator is also responsible for obtaining (hiring or finding volunteer) qualified officials and scorers for all matches. (Some of the Societies may have such personnel, but they should come from different divisions, so that they can play in their own division.)

EQUIPMENT:

Competition volleyball nets with steel cables and antennae, capable of being set at the various heights needed (7' 11 5/8", 7' 9 5/8", 7' 4 1/8" and 7' 2 1/8") for the different divisions are required. Adequate padding of the

poles is also required, along with referees stands, scoring tables and visual scoring devices (flip scorers) for each court.

Also needed are schedules, score sheets, line up sheets, and volleyballs (preferably Tachikara SV5WG or equivalent). It is recommended that medical coverage should be available on site. A copy of the current USA Volleyball rule book should be available for reference.

SECTION II DIAGRAMS

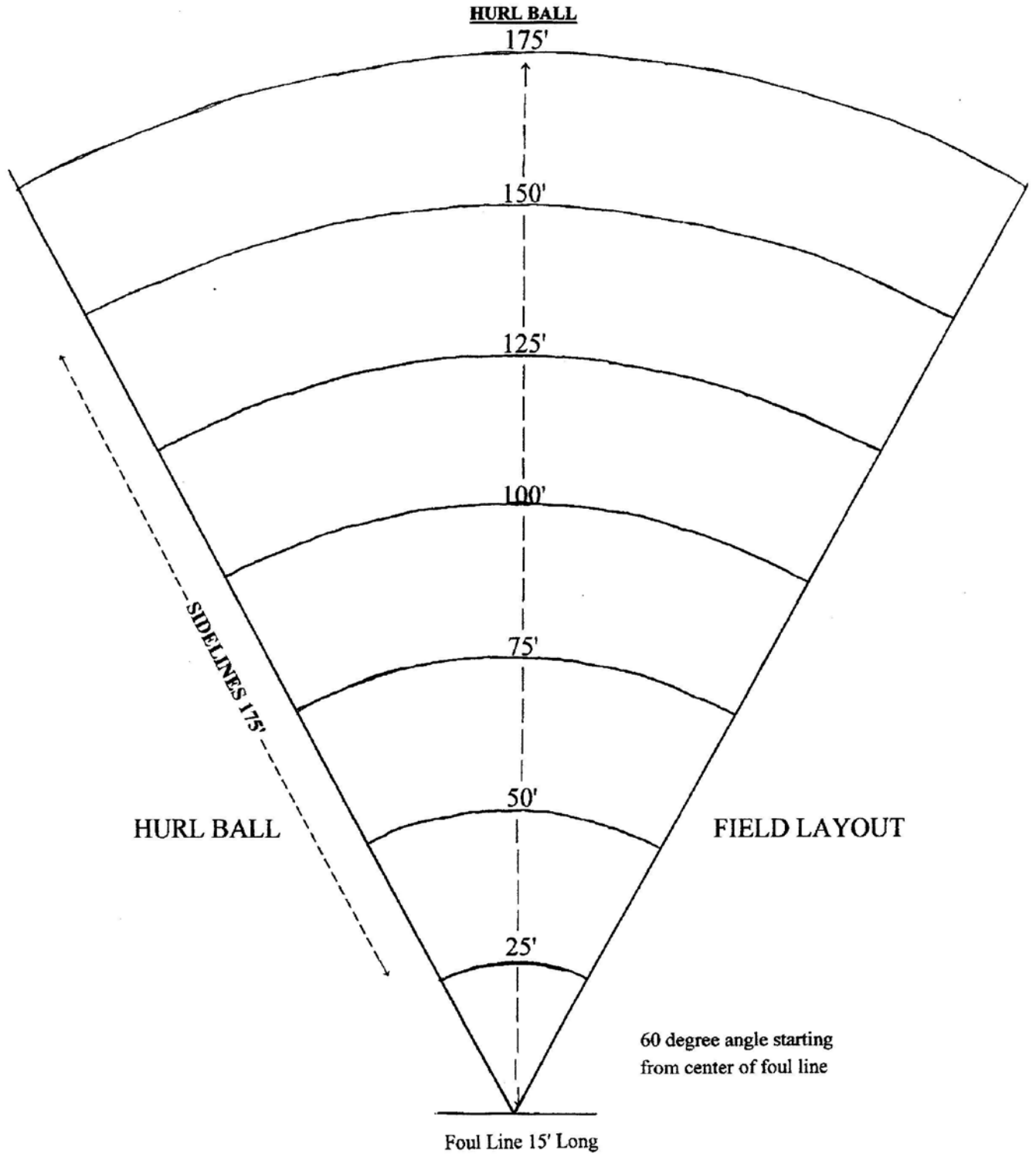

SHOT PUT

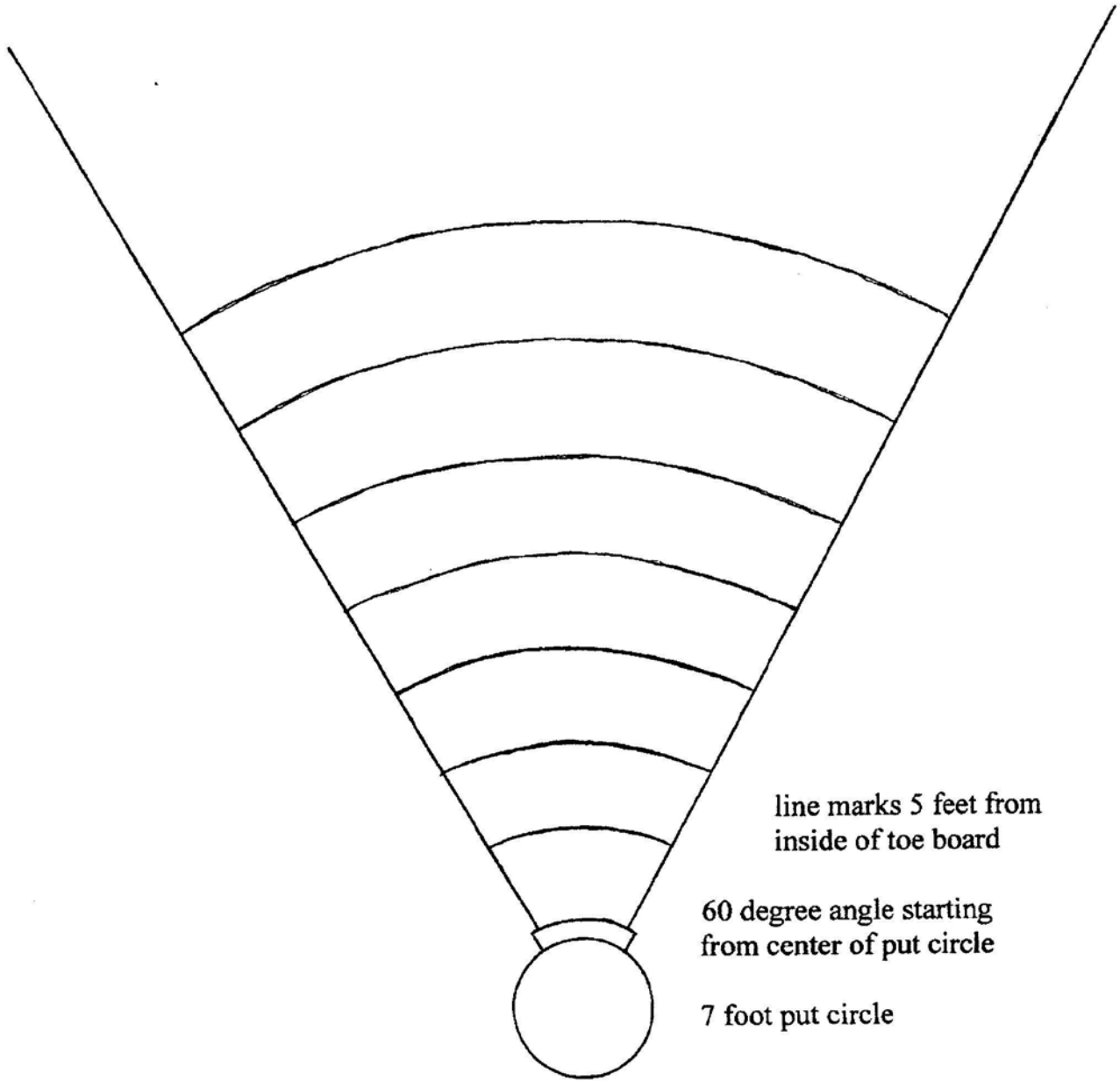

line marks 5 feet from
inside of toe board

60 degree angle starting
from center of put circle

7 foot put circle

SOFTBALL ACCURACY THROW TARGET

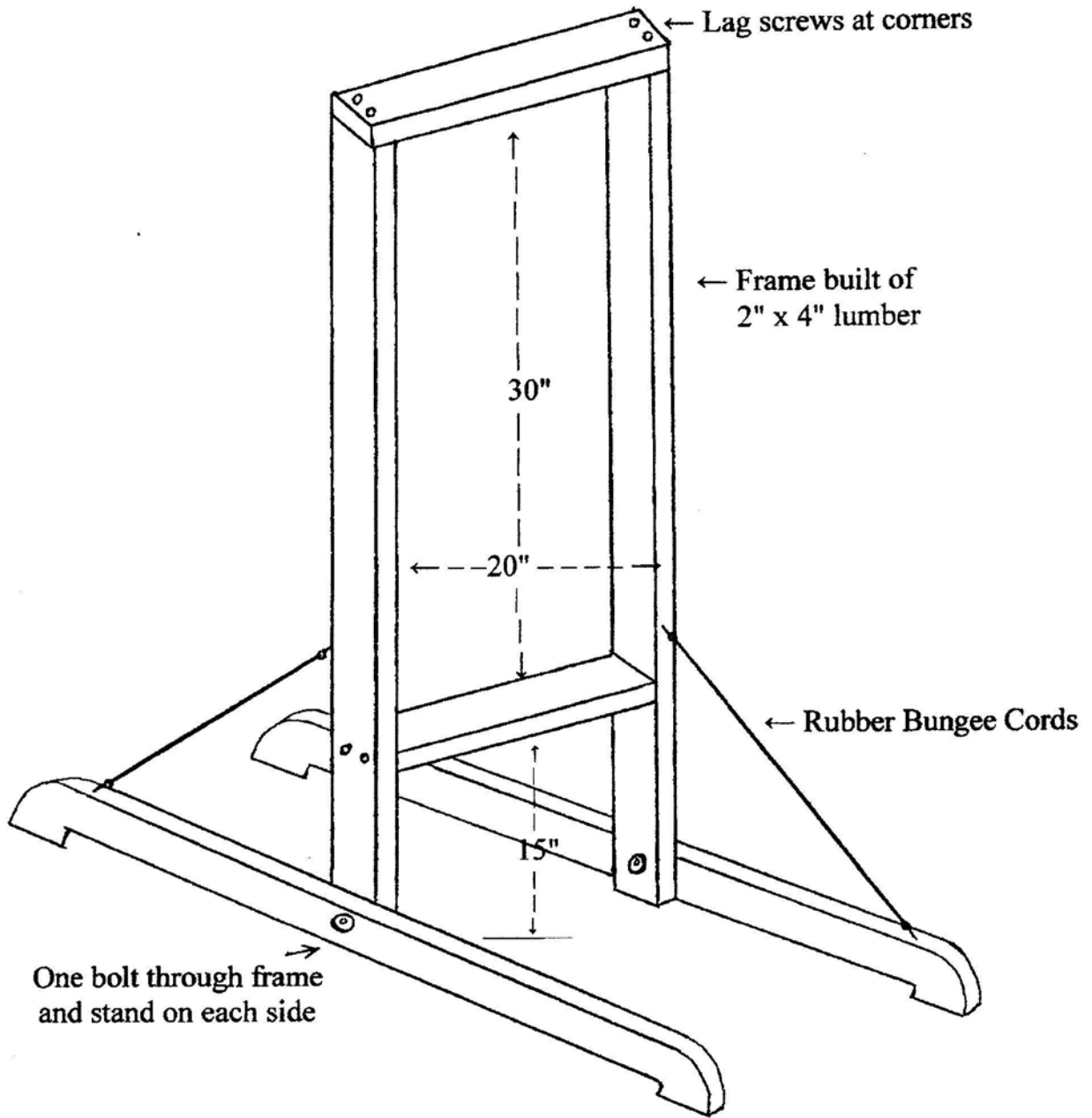

(For Official Festival Use Only) **SOCIETY NUMBER** _____ **INDIVIDUAL NUMBER** _____

NOTE: TO COMPETE IN ATHLETIC EVENTS, THIS PAGE MUST BE FILLED OUT, SIGNED AND RETURNED ALONG WITH THE "INDIVIDUAL" REGISTRATION SHEET AND PAYMENT.

FILL IN ALL SECTIONS! Refer to next two pages for events and corresponding event number.
PHOTOCOPIES MAY BE USED! *Suggestion...MAKE A COPY FOR YOUR OWN USE!*

NAME _____ SOCIETY _____

STREET _____ CITY _____ ZIP CODE _____

PHONE (____) _____ TURNER MEMBERSHIP CARD # _____ OR PARENTS # _____

AGE: _____ AGE GROUP LETTER: _____ GYMNASTIC LEVEL : _____
(as of 1st day of Festival) (Ages 7-29 only)

		---For Official Use Only---		
	NAME OF EVENT ENTERED	No. of Event	Ribbon Won	Audit
1				
2				
3				
4				
5				
6				
7				
8				
9				
10				
11				
12				
13				
14				
15				
16				
17				
18				
19				
20				
21				
22				
23				
24				

| --- For Official Use Only --- |

I ACCEPT and ABIDE by the Festival Rules _____ **Date** _____

ATHLETIC EVENTS of AMERICAN TURNERS for the NATIONAL FESTIVAL

Rules and Regulations for All Athletic Festival Events

Please Read Carefully NOTE: FOR COMPETITIVE RULES FOR EACH EVENT, PLEASE REFER TO THE NATIONAL FESTIVAL RULEBOOK!

- **Registration Deadlines:** It is necessary to enforce the deadlines for entries. Please read Page 1 of the Registration Form concerning deadline and late fee penalties. ***NOTHING ACCEPTED AFTER 35 DAYS PRIOR!***
- All pages of the Registration Form are for each individual competing in the Festival. Therefore, copies can be made for other members of your Society. Please read all pages carefully before filling out the form.
- **Waiver and Release Form:** Must be read, signed and dated when returning the Registration Form. NO registration will be accepted unless this waiver is completed. Please complete all the information regarding competitor, spectator, clothing size and banquet fees.
- **No form will be accepted without the designated fees.**

GYMNASTICS (see complete rules in the National Festival Rules book)

Competition Levels: 7-29 only Women – J.O. Levels 3,4,5 or Xcel Bronze, Silver, Gold, Platinum Diamond
Men – J.O. Levels 4,5,6,7,8,9,10

Note: there are no levels of difficulty in the Senior Divisions, both Men and Women.

WOMEN (maximum of 4 choices)

- | | |
|--------------------------------|----------|
| 1. Vault | All Ages |
| 2. Uneven Bars | All Ages |
| 3. Floor Exercise | All Ages |
| 4. High Beam | All Ages |
| 5. Low Beam | 30+ |
| 6. Parallel Bars | 40+ |
| 7. Pommel Horse | 40+ |
| 8. Rhythmic exercise, Optional | 60+ |

(Max. 1 min. - Rope, Ball, Ribbon, Clubs or Hoop)

MEN (maximum of 4 choices)

- | | |
|---|----------|
| 9. Vault | All Ages |
| 10. High Bar | All Ages |
| 11. Still Rings | All Ages |
| 12. Floor Exercise | All Ages |
| 13. Pommel Horse | All Ages |
| 14. Parallel Bars | All Ages |
| 15. 2 nd Optional on ONE event | 60+ |

TRACK & FIELD (maximum of 4 choices) **Must include a jump, run & throw for All-around requirements.**

WOMEN (Four Events)

- | | |
|-----------------------------|-------|
| 16. 50 M Dash | 7-9 |
| 17. 100 M Dash | 10-29 |
| 18. Shot Put, 6 lb. | 10-13 |
| 19. Shot Put, 8 lb. | 14-29 |
| 20. Running Long Jump | 10-29 |
| 21. Standing Long Jump | 7-29 |
| 22. Hurl Ball | 10-29 |
| 23. Softball Distance Throw | 7-9 |

MEN (Four Events)

- | | |
|-----------------------------|-------|
| 24. 50 M Dash | 7-9 |
| 25. 100 M Dash | 10-29 |
| 26. Shot Put, 8 lb. | 10-13 |
| 27. Shot Put, 12 lb. | 14-17 |
| 28. Shot Put, 16 lb. | 18-29 |
| 29. Running Long Jump | 10-29 |
| 30. Standing Long Jump | 7-29 |
| 31. Hurl Ball | 10-29 |
| 32. Softball Distance Throw | 7-9 |

SENIOR TRACK & FIELD (maximum of 4 choices) **Must include a jump, run & throw for All-around requirements.**

WOMEN (Four Events)

- | | |
|-----------------------------|-------|
| 33. Standing Long Jump | 30+ |
| 34. Shot Put, 8 lb. | 30-59 |
| 35. Shot Put, 6 lb. | 60+ |
| 36. Hurl Ball | 30+ |
| 37. Softball Distance Throw | 30+ |
| 38. 50 M Dash | 30-39 |
| 39. 50 M Run/Walk | 40+ |

MEN (Four Events)

- | | |
|-----------------------------|-------|
| 40. Standing Long Jump | 30+ |
| 41. Shot Put, 12 lb. | 30-59 |
| 42. Shot Put, 8 lb. | 60+ |
| 43. Hurl Ball | 30+ |
| 44. Softball Distance Throw | 30+ |
| 45. 50 M Dash | 30-39 |
| 46. 50 M Run/Walk | 40+ |

SPECIAL EVENTS:

WOMEN		MEN	
47. 400 M Run	60+	69. 400 M Run	60+
48. 800 M Run	10-13,30-59	70. 800 M Run	10-13,30-59
49. 1500 M Run	14-29	71. 1500 M Run	14-29
50. 5K Run	10-13	72. 5K Run	10-13
51. 5K Run	14-29	73. 5K Run	14-29
52. 5K Run	30+	74. 5K Run	30+
53. Golf *	18+	75. Golf *	18+
54. Tumbling	7-13	76. Tumbling	7-13
55. Tumbling	14-29	77. Tumbling	14-29
56. Tumbling	30+	78. Tumbling	30+
57. 4x100 M Running Relay *	7-13	79. 4x100 M Running Relay *	7-13
58. 4x100 M Running Relay *	14-29	80. 4x100 M Running Relay *	14-29
59. 4x50 M Running Relay *	30+	81. 4x50 M Running Relay *	30+
60. 75 M Medley Relay (3) *	7-13	82. 75 M Medley Relay (3) *	7-13
61. 75 M Medley Relay (3) *	30+	83. 75 M Medley Relay (3) *	30+
62. 100 M Medley Relay (4) *	14-29	84. 100 M Medley Relay (4) *	14-29
63. 100 M Free Style Relay (4) *	7-13	85. 100 M Free Style Relay (4) *	7-13
64. 100 M Free Style Relay (4) *	30+	86. 100 M Free Style Relay (4) *	30+
65. 200 M Free Style Relay (4) *	14-29	87. 200 M Free Style Relay (4) *	14-29
66. Rhythmic, <i>Women ONLY</i> 7-13: <i>choose one:</i> Ball, Ribbon, Rope, Clubs, Hoop			
67. Rhythmic, <i>Women ONLY</i> 14-29: <i>choose one:</i> Ball, Ribbon, Rope, Clubs, Hoop			
68. Rhythmic, <i>Women ONLY</i> 30+: <i>choose one:</i> Ball, Ribbon, Rope, Clubs, Hoop			

* **Relays and Golf...**(all ages) *See additional Entry Form/Roster, which must also be submitted*

NOTE: A separate registration form is to be used for the Recreational Games, which include:

Tennis, Badminton, Handball & Racquetball.

SWIMMING & DIVING:

WOMEN		MEN	
88. 25 M Free Style	7-13	100. 25 M Free Style	7-13
89. 25 M Free Style	30+	101. 25 M Free Style	30+
90. 25 M. Breast Stroke	7-13	102. 25 M Breast Stroke	7-13
91. 25 M Breast Stroke	30+	103. 25 M Breast Stroke	30+
92. 25 M Back Stroke	7-13	104. 25 M Back Stroke	7-13
93. 25 M Back Stroke	30+	105. 25 M Back Stroke	30+
94. 50 M Free Style	14-29	106. 50 M Free Style	14-29
95. 50 M Breast Stroke	14-29	107. 50 M Breast Stroke	14-29
96. 50 M Back Stroke	14-29	108. 50 M Back Stroke	14-29
97. 50 M Butterfly Stroke	14-29	109. 50 M Butterfly Stroke	14-29
98. 100 M Free Style	14-29	110. 100 M Free Style	14-29
99. Diving	All Ages	111. Diving	All Ages

VOLLEYBALL: (11-80+, 5 Divisions, plus 3 divisions of Co-ed)

WOMEN		MEN	
112. Junior Women	11-17	115. Active+ Men	14+
113. Active+ Women	14+	116. Senior Men	55+
114. Senior Women	50+		
117. Co-ed 11-17	118. Co-ed 18+	119. Co-ed Senior (50+ for women and 55+ for men)	

See additional Volleyball Team Roster Form for listing name of Society and Team members.

DRILLS:

120. Marching & Society Free Exercise 7+
121. Model Drill 7+

AMERICAN TURNERS RECREATIONAL GAMES ENTRY FORM

SOCIETY _____

LAST NAME _____

FIRST NAME _____

ADDRESS _____

CITY _____ STATE _____ ZIP CODE _____

RECREATIONAL GAMES (circle any of the following events)

HANDBALL/RAQUETBALL TENNIS (singles only)

BADMINTON

**PLEASE ATTACH TO THE COMPLETED OFFICIAL INDIVIDUAL
REGISTRATION FORM.**

AMERICAN TURNERS FESTIVAL TRACK RELAY ROSTER

SOCIETY _____

Runners may only compete with their own gender and age groups.
For exceptions refer to page 29 #9g of the Festival Rulebook.

4 x 50 Meter Relay

	Name	Age Group	Gender
1			
2			
3			
4			
A			
A			

4 x 100 Meter Relay

	Name	Age Group	Gender
1			
2			
3			
4			
A			
A			

AMERICAN TURNERS FESTIVAL SWIMMING RELAY ROSTER

SOCIETY _____

Swimmers may only compete with their own gender and age groups.
 For exceptions refer to page 29 #8 h & i of the Festival Rulebook.

75 Meter Medley Relay

	Name	Age Group	Gender
1			
2			
3			
A			
A			

100 Meter Medley Relay

	Name	Age Group	Gender
1			
2			
3			
4			
A			
A			

100 Meter Freestyle Relay

	Name	Age Group	Gender
1			
2			
3			
4			
A			
A			

200 Meter Freestyle Relay

	Name	Age Group	Gender
1			
2			
3			
4			
A			
A			

AMERICAN TURNERS FESTIVAL GOLF REGISTRATION (3-day event)

SOCIETY _____

GOLFER'S NAME _____

DIVISION: Men Women Sr. Men Sr. Women Super Sr. Men
(circle one)

AVERAGE SCORE _____

ENTRY FEE PAID _____
(includes Golf course fee, Cart, Golf banquet, Golf awards)

AMERICAN TURNERS FESTIVAL VOLLEYBALL TEAM ROSTER

Team Name _____ Captain Name _____ Society/District/Conglomerate _____ Division (circle as needed)
 _____ Jr. W(11-17) Active+ W(14+) Sr. W(50+)
 _____ Active+ M(14+) Sr. M(55+)
 _____ Co-Ed (11-17) (18+) Sr. (W 50+ & M 55+)

	Name	d.o.b.	Society	Phone No.	E-mail Address	Mailing Address
1						
2						
3						
4						
5						
6						
7						
8						
9						
10						
11						
12						
A1						
A2						
A3						
Man						